

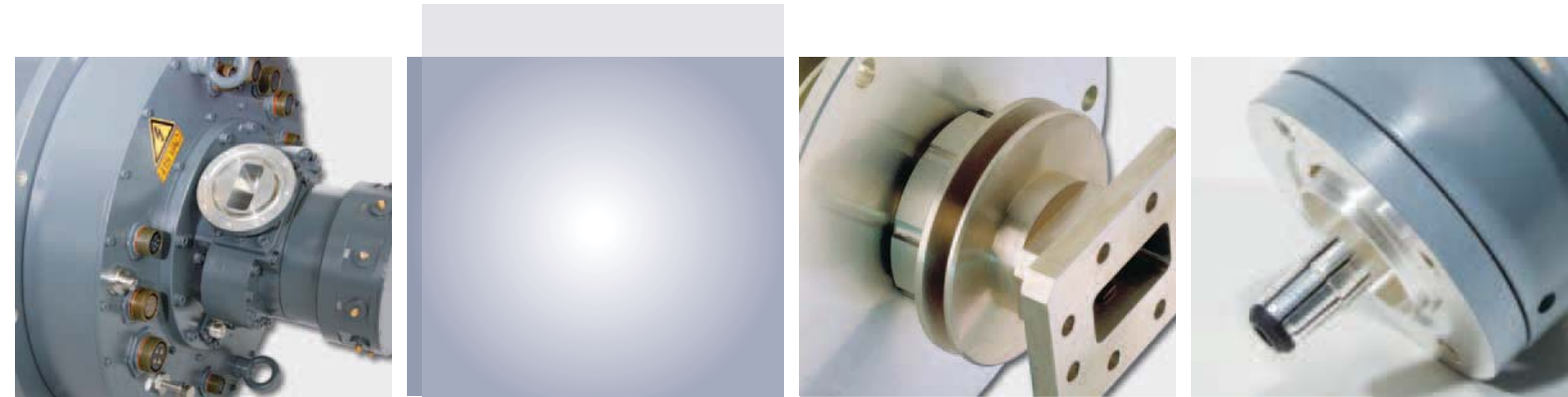

SPINNER || RADAR & SATELLITE



Edition B | 2012

- ONLINE UPDATE -

High Frequency Performance Worldwide
www.spinner-group.com



On our website you will find our latest updates.

As your contribution to environmental protection you can also download our catalogues as PDF files. This catalogue has been printed on wood-free Primaset paper.

The specifications given here as well as the illustrations are for advance information. They shall only be confirmed by SPINNER's written offer and are subject to technical amendments.

CONTENT

Combination of Rotary Joints..... 6

Fiber Optic Rotary Joints

 Single Channel Fiber Optic Rotary Joints..... 9

 Multichannel Fiber Optic Rotary Joints 12

Coax Rotary Joints

 Single Channel Coax Rotary Joints 18

 Dual Channel Coax Rotary Joints..... 47

Waveguide / Coax Rotary Joints

 3 Channel Coax Rotary Joints 67

Waveguide Rotary Joints

 Single Channel Waveguide Rotary Joints..... 75

 Dual Channel Waveguide Rotary Joints 103

Rotary Joints & Slip Rings Specification 108

Technical Annex 112

Index..... 122



Security is nowadays the key in a rapidly growing civilization. This affects air and naval traffic management as well as border security and remote communication. This relies mostly on highly sophisticated radar, communication and satellite systems.



As an international leader in innovation, SPINNER is a reliable supplier of advanced components for radar and satellite systems.

Since the early sixties SPINNER sets standards world-wide. Our innovations in this field together with our technical know-how and our top quality claim have allowed us to become one of the leading rotary joint manufacturers.

Rotary joints are needed wherever signals have to be transmitted between a fixed platform and a second platform in continuous rotation. Such applications include traditional radar technology for air traffic control or anti-missile defence, medical engineering, V-Sat and SatCom technology as well as industrial applications like TV camera systems or cable drums that allow sensitive cables to be wound up without twisting them, thus increasing their reliability.

Special benefits of SPINNER rotary joints are their compact design, excellent VSWR and low insertion loss, low variation of transmission properties during rotation, and high crosstalk attenuation between the individual channels over the whole frequency range.

The wealth of experience that our engineers have with rotary joints in extraterrestrial use and our commitment to continuous product improvement are the basis of our great success. When it comes to application in space, all major customers in Europe already trust in our rotary joints.





As an **additional service** SPINNER offers repair and maintenance of all rotary joint brands.

CUSTOM-MADE ROTARY JOINTS

For an enquiry to a custom-made rotary joint, our specification sheet assists you defining your system. Please find it at the end of this catalogue on page 108.

SPINNER | ROTARY JOINT SPECIFICATION

Company: _____ Customer Name: _____
 Address: _____ Phone No: _____
 E-Mail: _____
 Year Ref: _____ Date: _____

Project / Delivery Country: _____
 Application: Military use Marine Aeronautics Space RF rotary joint GPS rotary joint
 Industrial Agriculture Other: _____ Radar rotary joint Scanner

Required Quantity: _____ Part Number: _____ Serial: _____ Delivery Period: _____

GENERAL MECHANICAL DATA

Channel designation	1	2	3	4	5	6
Channel						
Stroke						
Rotational speed						
Drive power, max.						
Weight, approx. max.						
Stroke, max.						
Stroke low speed, max.						
Power, 50/60 Hz, max.						
Electrical power, max.						
Insulation, max.						
IP rating, max.						

GENERAL MECHANICAL DATA

Working speed, max. _____ rpm
 Stroke, max. _____ mm
 Stroke low speed, max. _____ mm
 Drive power, max. _____ W
 Weight, approx. max. _____ kg
 Stroke, max. _____ mm
 Stroke low speed, max. _____ mm
 Power, 50/60 Hz, max. _____ W
 Electrical power, max. _____ W
 Insulation, max. _____ V
 IP rating, max. _____

GENERAL ENVIRONMENTAL CONDITIONS

Operating temperature, max. _____ °C
 Storage temperature, max. _____ °C
 Humidity, max. _____ %
 Shock, max. _____ g
 Vibration, max. _____ g

DOCUMENTS REQUIRED

3D CAD drawing (STEP, IGES, etc.)
 Dimensional drawing
 Installation drawing
 Other: _____

Media joints

Highly integrated radar systems with radio frequency (RF) amplifiers right behind the rotating antenna often require access to cooling liquid. Media joint solutions, that transport cooling liquid or simply air through the joint to cool of active components, are available for intergration as well.

Non-contacting RF rotary joints

RF signals can be transmitted via axial and radial coupling structures. Non-contacting solutions have an excellent lifetime and are used for narrow band transmissions. Additionally, with special coupling structures, two different bands can be transmitted within one module (e.g. X- and L-Band).

Contacting RF rotary joints

The inner and outer conductors of stator and rotor are DC coupled. These rotary joints are used for broadband applications. If a coaxial structure is used, the cut-off frequency depends on the diameter of the coaxial line. In some cases, specially designed slip rings can be used at lower frequencies.



SINGLE CHANNEL & MULTICHANNEL FIBER OPTIC ROTARY JOINTS

Part number	Number of channel	Wavelength	Interfaces type / material	Page
BN 54 93 97	1	1310 nm / 1550 nm	LC-APC / ceramic	10
BN 52 90 13	1	850 nm / 1310 nm / 1550 nm	F-SMA-f	11
BN 54 97 57	4	1470 nm - 1650 nm	LC-APC / ceramic	12
BN 54 95 99	6	1310 nm / 1550 nm	LC-APC / ceramic	13
BN 54 95 81	12	1310 nm / 1550 nm	LC-APC / ceramic	14
BN 54 93 75	12	1310 nm / 1550 nm	E2000/APC R&M, SM 0.9 mm	15
BN 54 95 82	20	1310 nm	LC-APC / ceramic	16
BN 54 93 71	12 + 1 WG	1550 nm	E2000 / UBR100	17

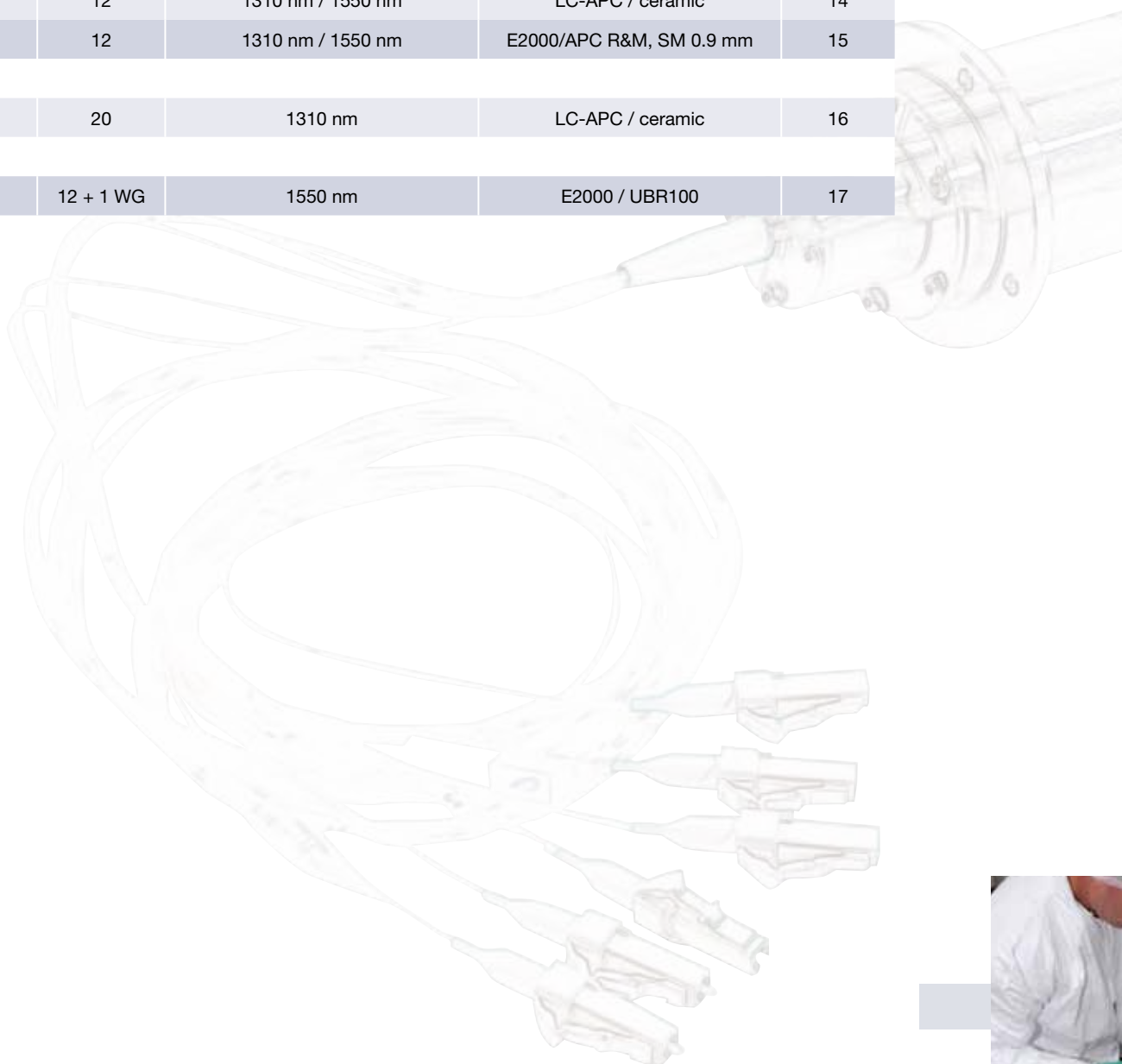

SINGLE CHANNEL & MULTICHANNEL FIBER OPTIC ROTARY JOINTS

Whether it is in industry or in the military sector the need to transmit ever increasing volumes of data with growing rates of data is getting bigger and bigger all the time. In the area of radar the trend of positioning the transmitter along with the signal generation directly on the turning antenna platform and realising the control via a rapid interference-proof optical data connection is gaining in importance.

SPINNER is following this trend and for this very purpose has developed a range of optical rotary joints which fulfil exactly this task either stand-alone or installed in hybrid RF rotary joints.

In the following section you can find optical single channel or multichannel rotary joints in single or multi-mode designs.

One highlight is the 6 channel rotary joint which was developed especially for the simultaneous transmission of analogue signals and which is currently the smallest of its kind on the worldwide market.

It goes without saying that the simultaneous transmission of analogue and (multiplexed) digital signals at a high decoupling and low insertion loss is also possible.

All parts of the rotary joints are manufactured on precision machines, with the assembly being completed in the clean room. This guarantees the consistently high quality of these maintenance-free, optical rotary joints.

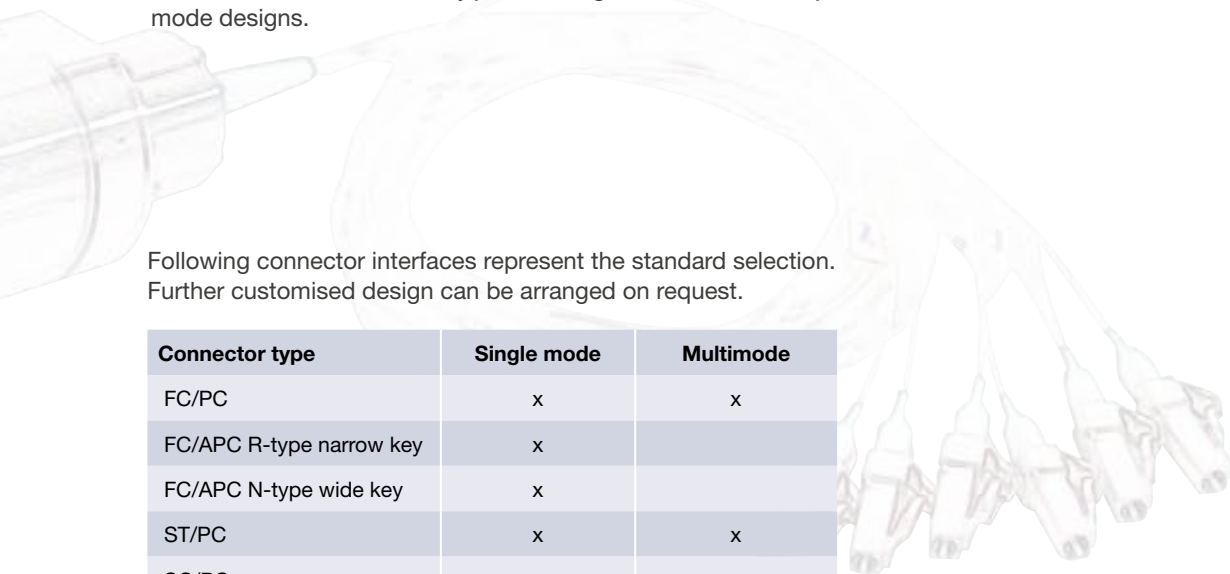

Following connector interfaces represent the standard selection. Further customised design can be arranged on request.

Connector type	Single mode	Multimode
FC/PC	x	x
FC/APC R-type narrow key	x	
FC/APC N-type wide key	x	
ST/PC	x	x
SC/PC	x	x
SC/APC	x	
LC/PC	x	x
LC/APC	x	
E-2000/PC	x	x
E-2000/APC	x	
FSMA		x



SINGLE CHANNEL FIBER OPTIC ROTARY JOINT

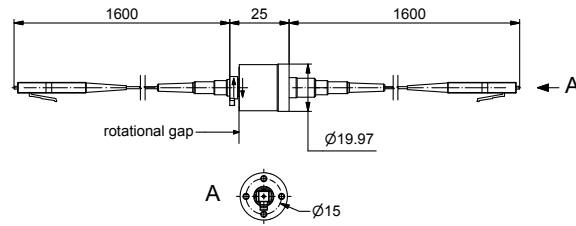

Fiber optic channel characteristics	BN 54 93 97
Interface type / material	LC-APC / ceramic
Fiber type	E9/125 , singlemode
Wavelength	1310 nm / 1550 nm
Return loss, min.	55 dB*
Insertion loss, max.	1 dB**
Insertion loss WOW, max.	0.5 dB**
Optical power, max.	200 mW / 23 dBm

* Measurement method acc. to standard IEC 61300-3-6 method 1

** Measurement method acc. to standard IEC 61300-3-4 insertion method (C).

General mechanical data	
Rotating speed, max.	2000 rpm
Life, min.	200 x 10 ⁶ revolutions
Starting torque, max.	0.06 Nm @ room temperature
Torque during rotation, max.	0.06 Nm @ room temperature
Case material	copper alloy, corrosion resistant
Case surface finish	no finish
Weight, approx.	0.06 kg

General environmental conditions	
Operation	
Ambient temperature range	-32 °C ... +71 °C
Temperature change	2 K/min
Relative humidity, max.	+27 °C / 98% +35 °C / 74%
IP protection level	IP62
Shock	typ. 30 g / 11 ms
Vibration (in three orthogonal axis)	6 to 17 m/s ² rms, 5.1 to 480 Hz, in three orthogonal axis
Storage	
Ambient temperature range	-40 °C ... +85 °C
Relative humidity, max.	95%

SINGLE CHANNEL FIBER OPTIC ROTARY JOINT

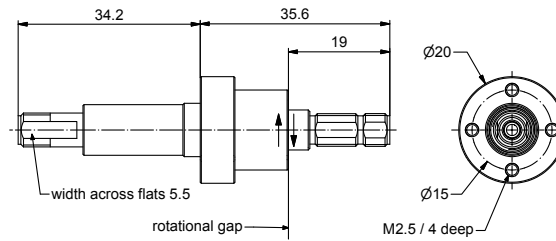

Fiber optic channel characteristics	BN 52 90 13
Interface type / material	F-SMA-f
Fiber type	G50/125 multimode
Wavelength	850 nm / 1310 nm / 1550 nm
Insertion loss, max.	2.0 dB
Insertion loss WOW, max.	0.5 dB
Optical power, max.	10 mW / 10 dBm

General mechanical data	
Rotating speed, max.	2000 rpm
Life, min.	200 x 10 ⁶ revolutions
Starting torque, max.	0.03 Nm @ room temperature
Torque during rotation, max.	0.03 Nm @ room temperature
Case material	stainless steel
Case surface finish	no finish
Weight, approx.	0.1 kg

General environmental conditions	
Operation	
Ambient temperature range	-40 °C ... +85 °C
Temperature change	2 K/min
Relative humidity, max.	95%
IP protection level	IP62
Storage	
Ambient temperature range	-40 °C ... +85 °C
Relative humidity, max.	95%

4 CHANNEL FIBER OPTIC ROTARY JOINT

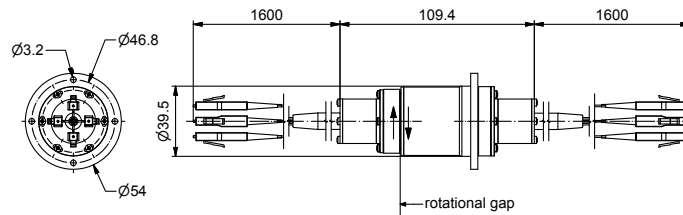

Fiber optic channel characteristics	BN 54 97 57
Interface type / material	LC-APC / ceramic
Fiber type	E9/125 , singlemode
Wavelength	1310 nm / 1550 nm
Return loss, min.	55 dB*
Insertion loss, max.	3.5 dB**
Insertion loss WOW, max.	1.5 dB**
Cross talk, min.	50 dB (between all channels)
Optical power, max.	200 mW / 23 dBm

* Measurement method acc. to standard IEC 61300-3-6 method 1

** Measurement method acc. to standard IEC 61300-3-4 insertion method (C).

General mechanical data	
Rotating speed, max.	100 rpm
Life, min.	10 x 10 ⁶ revolutions
Starting torque, max.	0.08 Nm @ room temperature
Torque during rotation, max.	0.08 Nm @ room temperature
Case material	stainless steel and copper alloy, corrosion resistant
Case surface finish	no finish
Weight, approx.	0.7 kg

General environmental conditions	
Operation	
Ambient temperature range	-40 °C ... +85 °C
Temperature change	2 K/min
Relative humidity, max.	95%
IP protection level	IP50
Shock	30 g typ. / 11 ms
Vibration	6 to 17 m/s ² rms, 5.1 to 480 Hz, in three orthogonal axis
Storage	
Ambient temperature range	-40 °C ... +85 °C
Relative humidity, max.	95%

6 CHANNEL FIBER OPTIC ROTARY JOINT

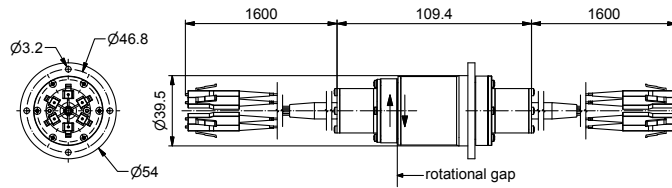

Fiber optic channel characteristics	BN 54 95 99
Interface type / material	LC-APC / ceramic
Fiber type	E9/125 , singlemode
Wavelength	1310 nm / 1550 nm
Return loss, min.	55 dB*
Insertion loss, max.	3.5 dB**
Insertion loss WOW, max.	1.5 dB**
Cross talk, min.	50 dB (between all channels)
Optical power, max.	200 mW / 23 dBm

* Measurement method acc. to standard IEC 61300-3-6 method 1

** Measurement method acc. to standard IEC 61300-3-4 insertion method (C).

General mechanical data	
Rotating speed, max.	100 rpm
Life, min.	10 x 10 ⁶ revolutions
Starting torque, max.	0.08 Nm @ room temperature
Torque during rotation, max.	0.08 Nm @ room temperature
Case material	stainless steel and copper alloy, corrosion resistant
Case surface finish	no finish
Weight, approx.	0.7 kg

General environmental conditions	
Operation	
Ambient temperature range	-40 °C ... +85 °C
Temperature change	2 K/min
Relative humidity, max.	95%
IP protection level	IP50
Shock	30 g typ. / 11 ms
Vibration	6 to 17 m/s ² rms, 5.1 to 480 Hz, in three orthogonal axis
Storage	
Ambient temperature range	-40 °C ... +85 °C
Relative humidity, max.	95%

12 CHANNEL FIBER OPTIC ROTARY JOINT

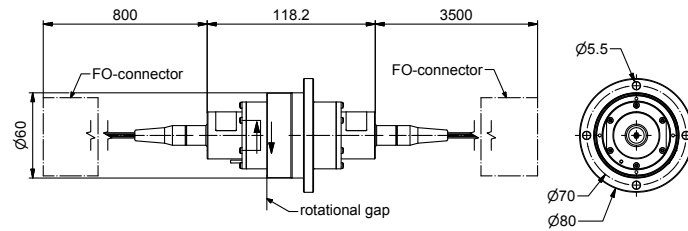

Fiber optic channel characteristics	BN 54 95 81
Interface type / material	LC-APC / ceramic
Fiber type	E9/125 , singlemode
Data transmission lines	12 x digital
Wavelength	1310 nm / 1550 nm
Return loss, min.	35 dB*
Insertion loss, max.	4.5 dB**
Insertion loss WOW, max.	2.5 dB**
Cross talk, min.	50 dB (between all channels)
Optical power, max.	200 mW / 23 dBm

* Measurement method acc. to standard IEC 61300-3-6 method 1

** Measurement method acc. to standard IEC 61300-3-4 insertion method (C).

General mechanical data	
Rotating speed, max.	100 rpm
Life, min.	10 x 10 ⁶ revolutions
Starting torque, max.	0.13 Nm @ room temperature
Torque during rotation, max.	0.13 Nm @ room temperature
Case material	stainless steel
Case surface finish	passivated
Weight, approx.	1.5 kg

General environmental conditions	
Operation	
Ambient temperature range	-40 °C ... +60 °C
Temperature change, max.	2 K/min
Relative humidity, max.	+27 °C / 98% +35 °C / 74%
IP protection level	IP50
Shock	30 g typ. / 11 ms
Vibration	3.85g rms typ., 5 Hz to 500 Hz
Storage	
Ambient temperature range	-40 °C ... +70 °C
Relative humidity, max.	95%

12 CHANNEL FIBER OPTIC ROTARY JOINT

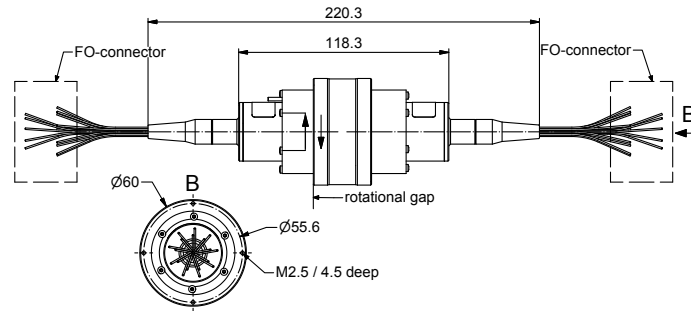

Fiber optic channel characteristics	BN 54 93 75
Interface type / material	E2000/APC R&M, SM 0.9 mm
Fiber type	E9/125 , singlemode
Data transmission lines / mode	4 x analog* / 12 x digital
Wavelength	1310 nm / 1550 nm
Return loss, min.	< 40dB @ +20 °C < 35dB @ -10 °C ... -40 °C
Insertion loss, max.	5.0 dB @ 1310 nm 3.5 dB @ 1550 nm
Insertion loss WOW, max.	3.0 dB @ 1310 nm 1.5 dB @ 1550 nm
Cross talk, min.	50 dB (between all channels)
Optical power, max.	10 mW / 10 dBm

* Max. insertion loss ripple within 5 deg. of rotation of analog transmission lines 0.1dB.
Analog transmission lines can also be used for digital transmission.

General mechanical data	
Rotating speed, max.	100 rpm
Life, min.	10 x 10 ⁶ revolutions
Starting torque, max.	0.13 Nm @ room temperature
Torque during rotation, max.	0.13 Nm @ room temperature
Case material	stainless steel
Case surface finish	passivated
Weight, approx.	1.5 kg

General environmental conditions	
Operation	
Ambient temperature range	-40 °C ... +60 °C
Temperature change, max.	2 K/min
Relative humidity, max.	+27 °C / 98% +35 °C / 74%
IP protection level	IP50
Shock	30 g typ. / 11 ms
Vibration	3.85g rms typ., 5 Hz to 500 Hz
Storage	
Ambient temperature range	-40 °C ... +70 °C
Relative humidity, max.	95%

20 CHANNEL FIBER OPTIC ROTARY JOINT

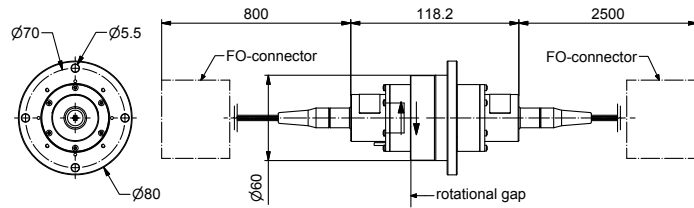
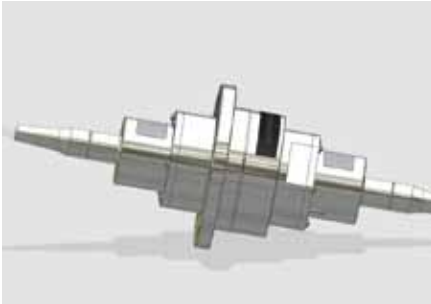

Fiber optic channel characteristics	BN 54 95 82
Interface type / material	LC-APC / ceramic
Fiber type	E9/125 , singlemode
Data transmission lines	20 x digital
Wavelength	1310 nm / 1550 nm
Return loss, min.	35 dB*
Insertion loss, max.	4.5 dB**
Insertion loss WOW, max.	2.5 dB**
Cross talk, min.	50 dB (between all channels)
Optical power, max.	200 mW / 23 dBm

* Measurement method acc. to standard IEC 61300-3-6 method 1

** Measurement method acc. to standard IEC 61300-3-4 insertion method (C).

General mechanical data	
Rotating speed, max.	100 rpm
Life, min.	10 x 10 ⁶ revolutions
Starting torque, max.	0.13 Nm @ room temperature
Torque during rotation, max.	0.13 Nm @ room temperature
Case material	stainless steel
Case surface finish	passivated
Weight, approx.	1.6 kg

General environmental conditions	
Operation	
Ambient temperature range	-40 °C ... +60 °C
Temperature change, max.	2 K/min
Relative humidity, max.	+27 °C / 98% +35 °C / 74%
IP protection level	IP50
Shock	30 g typ. / 11 ms
Vibration	3.85g rms typ., 5 Hz to 500 Hz
Storage	
Ambient temperature range	-40 °C ... +70 °C
Relative humidity, max.	95%

12 CHANNEL FIBER OPTICAL + SINGLE WAVEGUIDE ROTARY JOINT

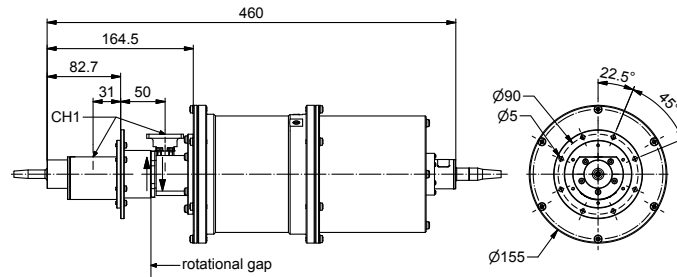

RF channel characteristics	BN 54 93 71
Interfaces	UBR 100 modified with threads M4
Style	U
Frequency range	8.5 - 10.5 GHz
Peak power, max.	15 kW*
Average power, max.	1000 W*
VSWR, max.	1.3
VSWR WOW, max.	0.05
Insertion loss, max.	0.25 dB
Insertion loss WOW, max.	0.05 dB

* Conditions: waveguide pressurized with dry air or N₂ or SF₆ at absolute pressure, min. 1 x 10⁵ Pa (1 bar)

Fiber optic channel characteristics	E2000
Interface type	E2000
Fiber type	E9/125, singlemode
Data transmission lines / mode	4 x analog* / 12 x digital
Wavelength	1550 nm
Return loss, min.	< 40dB @ +20 °C < 35dB @ -10 °C ... -40 °C
Insertion loss, max.	6.0 dB @ 1310 nm 4.5 dB @ 1550 nm
Insertion loss WOW, max.	3.0 dB @ 1310 nm 1.5 dB @ 1550 nm
Cross talk, min.	50 dB (between all channels)
Optical power, max.	10 mW / 10 dBm

* Max. insertion loss ripple within 5 deg. of rotation of analog transmission lines 0.1dB. Analog transmission lines can also be used for digital transmission.

General mechanical data	
Differential operating pressure, nom.	0.4 x 10 ⁵ Pa
Leakage rate, max.	50 cm ³ /minute @ nominal differential pressure
Rotating speed, max.	20 rpm
Life, min.	10 x 10 ⁶ revolutions
Case material	aluminum alloy
Case surface finish	chromate conversion coat
Weight, approx.	7.5 kg

General environmental conditions	
Operation	
Ambient temperature range	-40 °C ... +60 °C
Temperature change, max.	2 K/min
Relative humidity, max.	+27 °C / 98% +35 °C / 74%
IP protection level	IP50
Storage	
Ambient temperature range	-45 °C ... +70 °C
Temperature change, max.	2 K/min
Relative humidity, max.	95%

SINGLE CHANNEL COAX ROTARY JOINTS

Part number	Number of channel	Frequency range main channel	Interface	Page
BN 83 50 56	1	DC - 3.0 GHz	cable pigtail with right angle MMCX-m cable pigtail with MMCX-f	20
BN 83 50 58	1	DC - 3.0 GHz	cable pigtails with SMA-m (50 Ω)	21
BN 83 50 59	1	DC - 3.0 GHz	cable pigtails with SMA-m (50 Ω)	22
BN 83 50 62	1	DC - 3.0 GHz	cable pigtails with SMA-m (50 Ω)	23
BN 83 50 60	1	DC - 3.0 GHz	cable pigtails with SMA-m (50 Ω)	24
BN 83 50 50	1	DC - 3.0 GHz	cable pigtails with F-m (75 Ω)	25
BN 83 50 54	1	DC - 3.0 GHz	cable pigtails with F-m (75 Ω)	26
BN 83 50 55	1	DC - 3.0 GHz	cable pigtails with F-m (75 Ω)	27
BN 83 50 97	1	DC - 3.0 GHz	cable pigtails with F-m (75 Ω)	28
BN 83 50 44	1	1.525 - 1.661 GHz	cable pigtails with SMA-f / TNC (50 Ω)	29
BN 83 50 38	1	DC - 4.0 GHz	cable pigtails with SMA-m (50 Ω)	30
BN 83 50 47	1	DC - 18 GHz	SMA-f (50 Ω)	31
BN 83 50 98	1	DC - 18 GHz	SMA-f (50 Ω)	32
BN 83 50 68	1	DC - 26.5 GHz	3.5 mm-f (50 Ω)	33
BN 83 50 91	1	DC - 26.5 GHz	3.5 mm-f (50 Ω)	34
BN 83 50 45	1	DC - 40 GHz	2.92-f (50 Ω)	35
BN 83 50 77	1	DC - 50 GHz	2.4 mm-f (50 Ω)	36
BN 83 50 87	1	DC - 18 GHz	N-f (50 Ω)	37
BN 83 50 90	1	DC - 18 GHz	N-f (50 Ω)	38
BN 83 50 88	1	DC - 8 GHz	N-f (50 Ω) / N-m (50 Ω)	39
BN 94 54 21	1	DC - 5 GHz	N-f (50 Ω)	40
BN 94 54 36	1	DC - 5 GHz	7-16-f (50 Ω)	41
BN 94 54 20	1	2.8 - 3.4 GHz	7-16 (50 Ω)	42
BN 82 10 03	1	DC - 4 GHz	7/8" EIA (50 Ω)	43
BN 84 06 01	1	DC - 2.8 GHz	1 5/8" EIA (50 Ω)	44



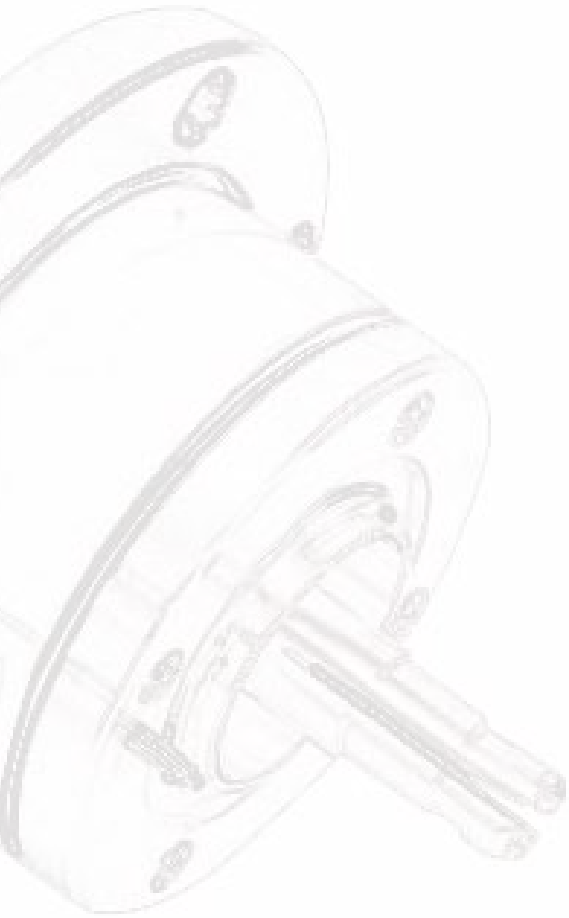

SINGLE CHANNEL COAX ROTARY JOINTS

In a variety of aerospace, maritime, industrial and automotive applications – in communication and radar systems, SPINNER's highly reliable coax rotary joints are part of the solution. Recently, several SatCom terminals and other mobile tracking platforms have been equipped with our low form factor designs.

Our standard portfolio consists of single, dual and 3 channel rotary joints in a frequency range from DC up to 50 GHz. We distinguish basically between **contacting** and **non-contacting** designs:

In case of **contacting** rotary joints, the inner and outer conductor of stator and rotor are DC coupled. These rotary joints are used for broadband applications. If a coaxial structure is used, the cut-off frequency depends on the diameter of the coaxial line.

In case of non-contacting rotary joints, RF signals can be transmitted via axial or radial coupling structures. Non-contacting solutions have an excellent lifetime and RF performance for narrow band transmission.

On customer request, coaxial rotary joints can be combined excellently with slip rings for additional low frequency data or power transmission, as well as with Fast Ethernet modules and other transmission modules.



SINGLE CHANNEL COAX ROTARY JOINT

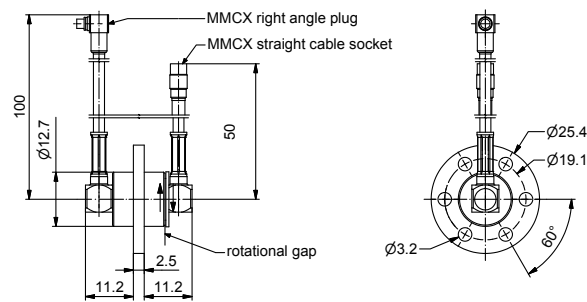

RF channel characteristics	BN 83 50 56
Interfaces	stator side: cable pigtail with right angle MMCX-m (50 Ω) rotor side: cable pigtail with MMCX-f (50 Ω)
Style	U
Frequency range	DC - 3.0 GHz
Average power, max.	18 W
VSWR, max.	1.35
VSWR WOW, max.	0.2
Insertion loss, max.	0.3 dB @ DC ≤ f ≤ 1 GHz 0.4 dB @ 1 < f ≤ 2 GHz 0.5 dB @ 2 < f ≤ 3 GHz
Insertion loss WOW, max.	0.2 dB
DC carrying capability	0.5 A @ 48 VDC, full RF avg. power 2.0 A @ 48 VDC, RF avg. power 1 W

General mechanical data	
Rotating speed, max.	60 rpm
Life, min.	0.25 x 10 ⁶ revolutions
Starting torque, max.	0.05 Nm @ room temperature
Torque during rotation, max.	0.05 Nm @ room temperature
Case material	copper alloy
Case surface finish	partially silver, nickel, tin plated
Connector material	copper alloy
Connector surface finish	gold plated
Weight, approx.	0.04 kg

General environmental conditions	
Operation	
Ambient temperature range	-40 °C ... +85 °C
Relative humidity, max.	95%
IP protection level	IP40
Storage	
Ambient temperature range	-40 °C ... +85 °C
Relative humidity, max.	95%

SINGLE CHANNEL COAX ROTARY JOINT

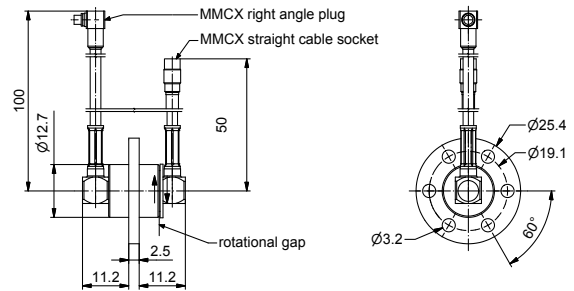

RF channel characteristics	BN 83 50 56
Interfaces	stator side: cable pigtail with right angle MMCX-m (50 Ω) rotor side: cable pigtail with MMCX-f (50 Ω)
Style	X
Frequency range	DC - 2.0 GHz
Average power, max.	18 W
VSWR, max.	1.35
VSWR WOW, max.	0.2
Insertion loss, max.	0.3 dB @ DC ≤ f ≤ 1 GHz 0.4 dB @ 1 < f ≤ 2 GHz 0.5 dB @ 2 < f ≤ 3 GHz
Insertion loss WOW, max.	0.2 dB
DC carrying capability	0.5 A @ 48 VDC, full RF avg. power 2.0 A @ 48 VDC, RF avg. power 1 W

General mechanical data	
Rotating speed, max.	60 rpm
Life, min.	0.25 x 10 ⁶ revolutions
Starting torque, max.	0.05 Nm @ room temperature
Torque during rotation, max.	0.05 Nm @ room temperature
Case material	copper alloy
Case surface finish	partially silver, nickel, tin plated
Connector material	copper alloy
Connector surface finish	gold plated
Weight, approx.	0.04 kg

General environmental conditions	
Operation	
Ambient temperature range	-40 °C ... +85 °C
Relative humidity, max.	95%
IP protection level	IP40
Storage	
Ambient temperature range	-40 °C ... +85 °C
Relative humidity, max.	95%

SINGLE CHANNEL COAX ROTARY JOINT

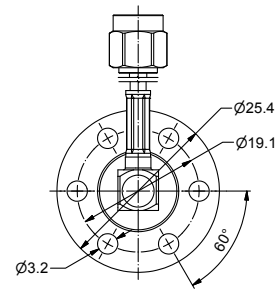
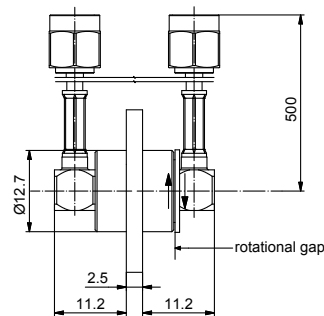

RF channel characteristics	BN 83 50 58
Interfaces	cable pigtailed with SMA-m (50 Ω)
Style	U
Frequency range	DC - 3.0 GHz
Average power, max.	18 W
VSWR, max.	1.35
VSWR WOW, max.	0.2
Insertion loss, max.	1.1 dB @ DC ≤ f ≤ 1.0 GHz 1.5 dB @ 1.0 < f ≤ 2.0 GHz 1.7 dB @ 2.0 < f ≤ 2.5 GHz 1.9 dB @ 2.5 < f ≤ 3.0 GHz
Insertion loss WOW, max.	0.2 dB
DC carrying capability	0.5 A @ 48 VDC, full RF avg. power 2.0 A @ 48 VDC, RF avg. power 1 W

General mechanical data	
Rotating speed, max.	60 rpm
Life, min.	0.25 x 10 ⁶ revolutions
Starting torque, max.	0.05 Nm @ room temperature
Torque during rotation, max.	0.05 Nm @ room temperature
Case material	copper alloy
Case surface finish	partially silver, nickel, tin plated
Connector material	copper alloy
Connector surface finish	gold plated
Weight, approx.	0.04 kg

General environmental conditions	
Operation	
Ambient temperature range	-40 °C ... +85 °C
Relative humidity, max.	95%
IP protection level	IP40
Storage	
Ambient temperature range	-40 °C ... +85 °C
Relative humidity, max.	95%

SINGLE CHANNEL COAX ROTARY JOINT

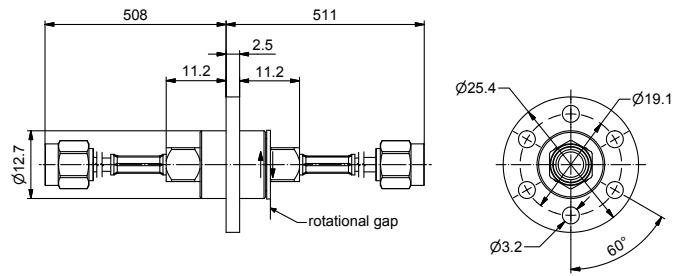

RF channel characteristics	BN 83 50 59
Interfaces	cable pigtailed with SMA-m (50 Ω)
Style	I
Frequency range	DC - 3.0 GHz
Average power, max.	18 W
VSWR, max.	1.35
VSWR WOW, max.	0.2
Insertion loss, max.	1.1 dB @ DC ≤ f ≤ 1.0 GHz 1.5 dB @ 1.0 < f ≤ 2.0 GHz 1.7 dB @ 2.0 < f ≤ 2.5 GHz 1.9 dB @ 2.5 < f ≤ 3.0 GHz
Insertion loss WOW, max.	0.2 dB
DC carrying capability	0.5 A @ 48 VDC, full RF avg. power 2.0 A @ 48 VDC, RF avg. power 1 W

General mechanical data	
Rotating speed, max.	60 rpm
Life, min.	0.25 x 10 ⁶ revolutions
Starting torque, max.	0.05 Nm @ room temperature
Torque during rotation, max.	0.05 Nm @ room temperature
Case material	copper alloy
Case surface finish	partially silver, nickel, tin plated
Connector material	copper alloy
Connector surface finish	gold plated
Weight, approx.	0.04 kg

General environmental conditions	
Operation	
Ambient temperature range	-40 °C ... +85 °C
Relative humidity, max.	95%
IP protection level	IP40
Storage	
Ambient temperature range	-40 °C ... +85 °C
Relative humidity, max.	95%

SINGLE CHANNEL COAX ROTARY JOINT

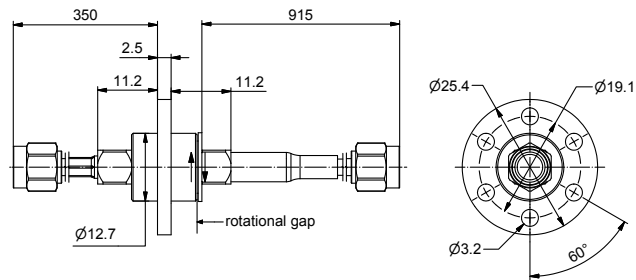

RF channel characteristics	BN 83 50 62
Interfaces	cable pigtailed with SMA-m (50 Ω)
Style	I
Frequency range	DC - 3.0 GHz
Average power, max.	18 W
VSWR, max.	1.35
VSWR WOW, max.	0.2
Insertion loss, max.	1.5 dB @ DC ≤ f ≤ 1.0 GHz 2.0 dB @ 1.0 < f ≤ 2.0 GHz 2.2 dB @ 2.0 < f ≤ 2.5 GHz 2.4 dB @ 2.5 < f ≤ 3.0 GHz
Insertion loss WOW, max.	0.2 dB
DC carrying capability	0.5 A @ 48 VDC, full RF avg. power 2.0 A @ 48 VDC, RF avg. power 1 W

General mechanical data	
Rotating speed, max.	60 rpm
Life, min.	0.25 x 10 ⁶ revolutions
Starting torque, max.	0.05 Nm @ room temperature
Torque during rotation, max.	0.05 Nm @ room temperature
Case material	copper alloy
Case surface finish	partially silver, nickel, tin plated
Connector material	copper alloy
Connector surface finish	gold plated
Weight, approx.	0.05 kg

General environmental conditions	
Operation	
Ambient temperature range	-40 °C ... +85 °C
Relative humidity, max.	95%
IP protection level	IP40
Storage	
Ambient temperature range	-40 °C ... +85 °C
Relative humidity, max.	95%

SINGLE CHANNEL COAX ROTARY JOINT

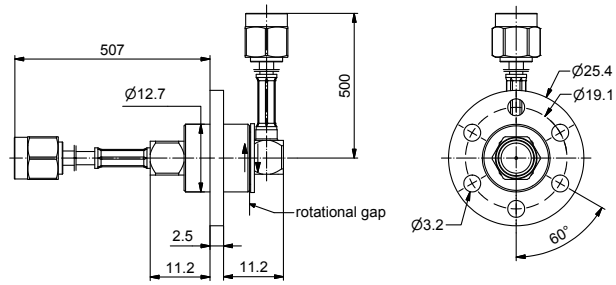

RF channel characteristics	BN 83 50 60
Interfaces	cable pigtails with SMA-m (50 Ω)
Style	L
Frequency range	DC - 3.0 GHz
Average power, max.	18 W
VSWR, max.	1.35
VSWR WOW, max.	0.2
Insertion loss, max.	1.1 dB @ DC ≤ f ≤ 1.0 GHz 1.5 dB @ 1.0 < f ≤ 2.0 GHz 1.7 dB @ 2.0 < f ≤ 2.5 GHz 1.9 dB @ 2.5 < f ≤ 3.0 GHz
Insertion loss WOW, max.	0.2 dB
DC carrying capability	0.5 A @ 48 VDC, full RF avg. power 2.0 A @ 48 VDC, RF avg. power 1 W

General mechanical data	
Rotating speed, max.	60 rpm
Life, min.	0.25 x 10 ⁶ revolutions
Starting torque, max.	0.05 Nm @ room temperature
Torque during rotation, max.	0.05 Nm @ room temperature
Case material	copper alloy
Case surface finish	partially silver, nickel, tin plated
Connector material	copper alloy
Connector surface finish	gold plated
Weight, approx.	0.04 kg

General environmental conditions	
Operation	
Ambient temperature range	-40 °C ... +85 °C
Relative humidity, max.	95%
IP protection level	IP40
Storage	
Ambient temperature range	-40 °C ... +85 °C
Relative humidity, max.	95%

SINGLE CHANNEL COAX ROTARY JOINT

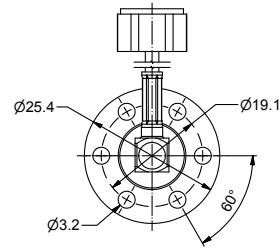
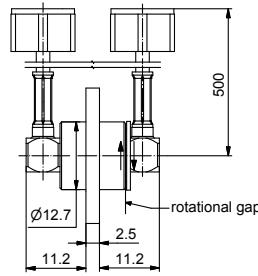

RF channel characteristics	BN 83 50 50
Interfaces	cable pigtailed with F-m (75 Ω)
Style	U
Frequency range	DC - 3.0 GHz
Average power, max.	18 W
VSWR, max.	1.25 @ DC ≤ f ≤ 1.0 GHz 1.35 @ 1.0 < f ≤ 2.0 GHz 1.45 @ 2.0 < f ≤ 2.5 GHz 1.55 @ 2.5 < f ≤ 3.0 GHz
VSWR WOW, max.	0.2
Insertion loss, max.	1.1 dB @ DC ≤ f ≤ 1.0 GHz 1.5 dB @ 1.0 < f ≤ 2.0 GHz 1.7 dB @ 2.0 < f ≤ 2.5 GHz 1.9 dB @ 2.5 < f ≤ 3.0 GHz
Insertion loss WOW, max.	0.2 dB
DC carrying capability	0.5 A @ 48 VDC, full RF avg. power 2.0 A @ 48 VDC, RF avg. power 1 W

General mechanical data	
Rotating speed, max.	60 rpm
Life, min.	0.25 x 10 ⁵ revolutions
Starting torque, max.	0.05 Nm @ room temperature
Torque during rotation, max.	0.05 Nm @ room temperature
Case material	copper alloy
Case surface finish	partially silver, nickel, tin plated
Weight, approx.	0.04 kg

General environmental conditions	
Operation	
Ambient temperature range	-40 °C ... +85 °C
Relative humidity, max.	95%
IP protection level	IP40
Storage	
Ambient temperature range	-40 °C ... +85 °C
Relative humidity, max.	95%

SINGLE CHANNEL COAX ROTARY JOINT

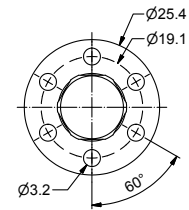
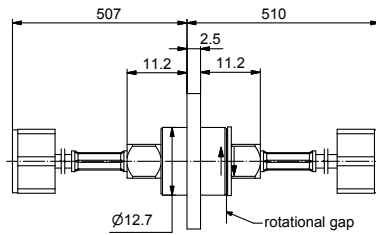

RF channel characteristics	BN 83 50 54
Interfaces	cable pigtailed with F-m (75 Ω)
Style	I
Frequency range	DC - 3.0 GHz
Average power, max.	18 W
VSWR, max.	1.25 @ DC ≤ f ≤ 1.0 GHz 1.35 @ 1.0 < f ≤ 2.0 GHz 1.45 @ 2.0 < f ≤ 2.5 GHz 1.55 @ 2.5 < f ≤ 3.0 GHz
VSWR WOW, max.	0.2
Insertion loss, max.	1.1 dB @ DC ≤ f ≤ 1.0 GHz 1.5 dB @ 1.0 < f ≤ 2.0 GHz 1.7 dB @ 2.0 < f ≤ 2.5 GHz 1.9 dB @ 2.5 < f ≤ 3.0 GHz
Insertion loss WOW, max.	0.2 dB
DC carrying capability	0.5 A @ 48 VDC, full RF avg. power 2.0 A @ 48 VDC, RF avg. power 1 W

General mechanical data	
Rotating speed, max.	60 rpm
Life, min.	0.25 x 10 ⁵ revolutions
Starting torque, max.	0.05 Nm @ room temperature
Torque during rotation, max.	0.05 Nm @ room temperature
Case material	copper alloy
Case surface finish	partially silver, nickel, tin plated
Weight, approx.	0.04 kg

General environmental conditions	
Operation	
Ambient temperature range	-40 °C ... +85 °C
Relative humidity, max.	95%
IP protection level	IP40
Storage	
Ambient temperature range	-40 °C ... +85 °C
Relative humidity, max.	95%

SINGLE CHANNEL COAX ROTARY JOINT

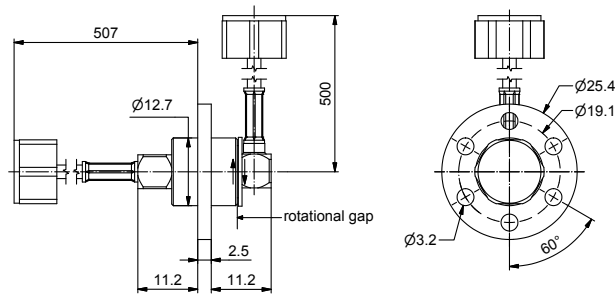

RF channel characteristics	BN 83 50 55
Interfaces	cable pigtails with F-m (75 Ω)
Style	L
Frequency range	DC - 3.0 GHz
Average power, max.	18 W
VSWR, max.	1.25 @ DC ≤ f ≤ 1.0 GHz 1.35 @ 1.0 < f ≤ 2.0 GHz 1.45 @ 2.0 < f ≤ 2.5 GHz 1.55 @ 2.5 < f ≤ 3.0 GHz
VSWR WOW, max.	0.2
Insertion loss, max.	1.0 dB @ DC ≤ f ≤ 1.0 GHz 1.5 dB @ 1.0 < f ≤ 2.0 GHz 1.7 dB @ 2.0 < f ≤ 2.5 GHz 1.9 dB @ 2.5 < f ≤ 3.0 GHz
Insertion loss WOW, max.	0.2 dB
DC carrying capability	0.5 A @ 48 VDC, full RF avg. power 2.0 A @ 48 VDC, RF avg. power 1 W

General mechanical data	
Rotating speed, max.	60 rpm
Life, min.	0.25 x 10 ⁵ revolutions
Starting torque, max.	0.05 Nm @ room temperature
Torque during rotation, max.	0.05 Nm @ room temperature
Case material	copper alloy
Case surface finish	partially silver, nickel, tin plated
Weight, approx.	0.04 kg

General environmental conditions	
Operation	
Ambient temperature range	-40 °C ... +85 °C
Relative humidity, max.	95%
IP protection level	IP40
Storage	
Ambient temperature range	-40 °C ... +85 °C
Relative humidity, max.	95%

SINGLE CHANNEL COAX ROTARY JOINT

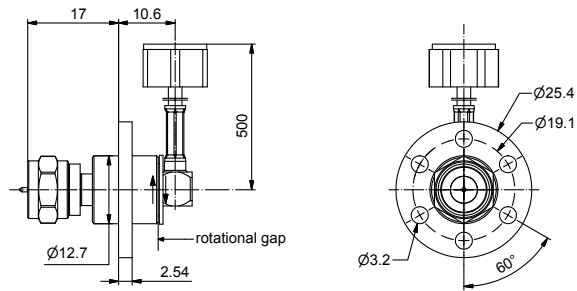

RF channel characteristics	BN 83 50 97
Interfaces	cable pigtails with F-m (75 Ω)
Style	L
Frequency range	DC - 3.0 GHz
Average power, max.	18 W
VSWR, max.	1.20 @ DC ≤ f ≤ 1.0 GHz 1.30 @ 1.0 < f ≤ 2.0 GHz 1.35 @ 2.0 < f ≤ 2.5 GHz 1.40 @ 2.5 < f ≤ 3.0 GHz
VSWR WOW, max.	0.2
Insertion loss, max.	0.6 @ DC ≤ f ≤ 1.0 GHz 0.8 @ 1.0 < f ≤ 2.0 GHz 1.0 @ 2.0 < f ≤ 2.5 GHz 1.2 @ 2.5 < f ≤ 3.0 GHz
Insertion loss WOW, max.	0.2 dB
DC carrying capability	0.5 A @ 48 VDC, full RF avg. power 2.0 A @ 48 VDC, RF avg. power 1 W

General mechanical data	
Rotating speed, max.	60 rpm
Life, min.	0.25 x 10 ⁶ revolutions
Starting torque, max.	0.05 Nm @ room temperature
Torque during rotation, max.	0.05 Nm @ room temperature
Weight, approx.	0.04 kg

General environmental conditions	
Operation	
Ambient temperature range	-40 °C ... +85 °C
Relative humidity, max.	95%
IP protection level	IP40
Storage	
Ambient temperature range	-40 °C ... +85 °C
Relative humidity, max.	95%

SINGLE CHANNEL COAX ROTARY JOINT

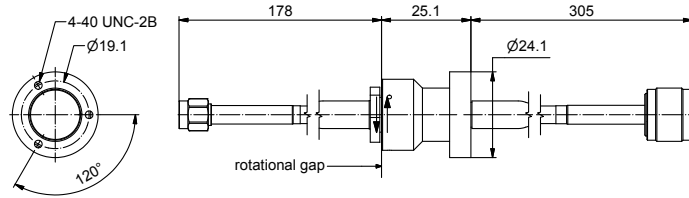

RF channel characteristics	BN 83 50 44
Interfaces	cable pigtailed with SMA-f (50 Ω) / TNC (50 Ω)
Style	I
Frequency range	1.525 - 1.661 GHz
Average power, max.	6 W
VSWR, max.	1.7
VSWR WOW, max.	0.05
Insertion loss, max.	1 dB
Insertion loss WOW, max.	0.1 dB
Phase WOW, max.	1 deg.

General mechanical data	
Rotating speed, max.	30 rpm
Life, min.	1 x 10 ⁶ revolutions
Starting torque, max.	0.04 Nm @ room temperature
Torque during rotation, max.	0.04 Nm @ room temperature
Case material	copper alloy
Case surface finish	tin plated
Weight, approx.	0.5 kg

General environmental conditions	
Operation	
Ambient temperature range	-25 °C ... +55 °C
Relative humidity, max.	95%
IP protection level	IP50
Storage	
Ambient temperature range	-35 °C ... +70 °C
Relative humidity, max.	95%

SINGLE CHANNEL COAX ROTARY JOINT

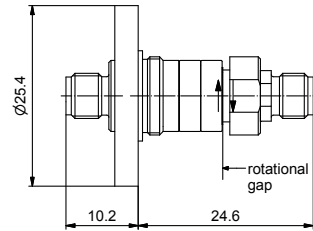
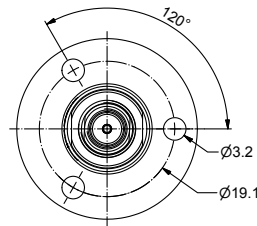

RF channel characteristics	BN 83 50 47
Interfaces	SMA-f (50 Ω)
Style	I
Frequency range	DC - 18 GHz
Peak power, max.	3 kW
Average power, max.	200 W @ 1 GHz 500 W @ 1 GHz* 40 W @ 15 GHz 100 W @ 15 GHz* 30 W @ 18 GHz
VSWR, max.	1.3 @ DC - 10 GHz 1.4 @ 10 to 18 GHz
VSWR WOW, max.	0.05
Insertion loss, max.	0.25 dB @ DC - 10 GHz 0.30 dB @ 10 to 18 GHz
Insertion loss WOW, max.	0.05 dB
Phase WOW, max.	1 deg.

* Conditions: Case temperature, max. +60 °C

General mechanical data	
Rotating speed, max.	500 rpm
Life, min.	5 x 10 ⁶ revolutions
Starting torque, max.	0.05 Nm @ room temperature
Torque during rotation, max.	0.05 Nm @ room temperature
Case material	copper alloy
Case surface finish	silver plated
Weight, approx.	0.028 kg

General environmental conditions	
Operation	
Ambient temperature range	-40 °C ... +70 °C
Relative humidity, max.	95%
IP protection level	IP40
Storage	
Ambient temperature range	-50 °C ... +70 °C
Relative humidity, max.	95%

SINGLE CHANNEL COAX ROTARY JOINT

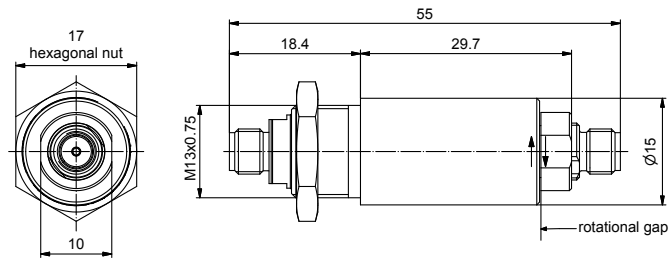

RF channel characteristics	BN 83 50 98
Interfaces	SMA-f (50 Ω)
Style	I
Frequency range	DC - 18 GHz
Peak power, max.	3 kW*
Average power, max.	150 W @ 1 GHz 30 W @ 18 GHz
VSWR, max.	1.3 @ DC - 10 GHz 1.4 @ 10 to 18 GHz
VSWR WOW, max.	0.05
Insertion loss, max.	0.30 @ DC - 10 GHz 0.35 @ 10 to 18 GHz
Insertion loss WOW, max.	0.1 dB

* Conditions: Load VSWR, max. 1.2; Pulse width, max. 2 µs; Pulse repetition rate, max. 3000 1/s

General mechanical data	
Rotating speed, max.	300 rpm
Life, min.	5 x 10 ⁶ revolutions
Starting torque, max.	0.05 Nm @ room temperature
Torque during rotation, max.	0.05 Nm @ room temperature
Case material	copper alloy
Case surface finish	silver plated
Weight, approx.	0.04 kg

General environmental conditions	
Operation	
Ambient temperature range	-40 °C ... +85 °C
Relative humidity, max.	95%
IP protection level	IP40
Storage	
Ambient temperature range	-40 °C ... +85 °C
Relative humidity, max.	95%

SINGLE CHANNEL COAX ROTARY JOINT

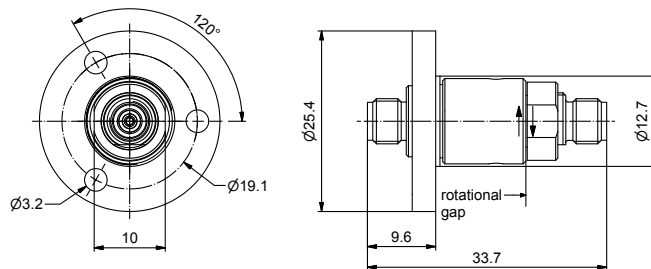

RF channel characteristics	BN 83 50 68
Interfaces	3.5 mm-f (50 Ω)
Style	I
Frequency range	DC - 26.5 GHz
Peak power, max.	3 kW @ sea level 90 W @ 55000 feet
Average power, max.	200 W @ 1 GHz 40 W @ 15 GHz 25 W @ 26.5 GHz
VSWR, max.	1.3 @ DC - 10 GHz 1.4 @ 10 - 18 GHz 1.7 @ 18 - 26.5 GHz
VSWR WOW, max.	0.05 @ DC - 18 GHz 0.10 @ 18 - 26.5 GHz
Insertion loss, max.	0.30 dB @ DC - 10 GHz 0.35 dB @ 10 - 18 GHz 0.70 dB @ 18 - 26.5 GHz
Insertion loss, typ.	0.5 dB @ 18 - 26.5 GHz
Insertion loss WOW, max.	0.1 dB @ DC - 18 GHz 0.2 dB @ 18 - 26.5 GHz
Phase WOW, max.	1.0 deg. @ DC - 10 GHz 1.5 deg. @ 10 - 18 GHz 2.0 deg. @ 18 - 26.5 GHz
General mechanical data	
Rotating speed, max.	200 rpm
Life, min.	5 x 10 ⁶ revolutions
Starting torque, max.	0.05 Nm @ room temperature
Torque during rotation, max.	0.05 Nm @ room temperature
Case material	copper alloy
Case surface finish	silver plated
Weight, approx.	0.028 kg
General environmental conditions	
Operation	
Ambient temperature range	-40 °C ... +70 °C
Relative humidity, max.	95%
IP protection level	IP40
Storage	
Ambient temperature range	-50 °C ... +70 °C
Relative humidity, max.	95%

SINGLE CHANNEL COAX ROTARY JOINT

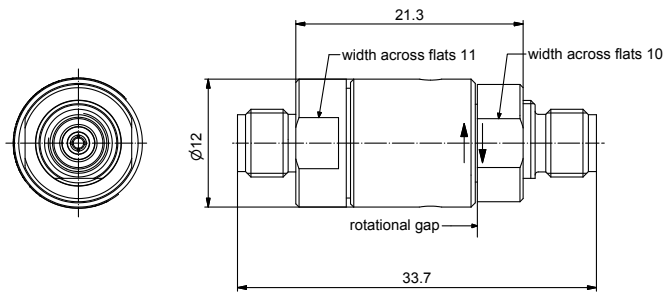

RF channel characteristics	BN 83 50 91
Interfaces	3.5 mm-f (50 Ω)
Style	I
Frequency range	DC - 26.5 GHz
Peak power, max.	3 kW @ sea level 90 W @ 55000 feet
Average power, max.	200 W @ 1 GHz 40 W @ 15 GHz 25 W @ 26.5 GHz
VSWR, max.	1.3 @ DC - 10 GHz 1.4 @ 10 - 18 GHz 1.7 @ 18 - 26.5 GHz
VSWR WOW, max.	0.05
Insertion loss, max.	0.30 dB @ DC to 10 GHz 0.35 dB @ 10 to 18 GHz 0.70 dB @ 18 to 26.5 GHz
Insertion loss WOW, max.	0.05 dB
Phase WOW, max.	1 deg.

General mechanical data	
Rotating speed, max.	500 rpm
Life, min.	5 x 10 ⁶ revolutions
Starting torque, max.	0.05 Nm @ room temperature
Torque during rotation, max.	0.05 Nm @ room temperature
Case material	copper alloy
Case surface finish	silver plated
Connector material	copper alloy
Connector surface finish	gold plated
Weight, approx.	0.02 kg

General environmental conditions	
Operation	
Ambient temperature range	-40 °C ... +70 °C
Relative humidity, max.	95%
IP protection level	IP40
Storage	
Ambient temperature range	-50 °C ... +70 °C
Relative humidity, max.	95%

SINGLE CHANNEL COAX ROTARY JOINT

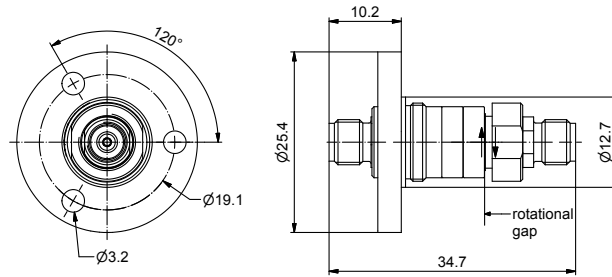

RF channel characteristics	BN 83 50 45
Interfaces	2.92-f (50 Ω)
Style	I
Frequency range	DC - 40 GHz
Peak power, max.	500 W* @ 1 GHz
Average power, max.	50 W @ DC - 2 GHz 20 W @ 2 - 4 GHz 5 W @ 4 - 10 GHz 2 W @ 10 - 18 GHz 1 W @ 18 - 40 GHz
VSWR, max.	1.3 @ DC - 10 GHz 1.4 @ 10 - 18 GHz 1.7 @ 18 - 26.5 GHz 2.0 @ 26.5 - 40 GHz
VSWR WOW, max.	0.1
Insertion loss, max.	0.5 dB @ DC - 18 GHz 1.0 dB @ 18 - 26.5 GHz 1.2 dB @ 26.5 - 40 GHz
Insertion loss WOW, max.	0.1 dB
Phase WOW, max.	3 deg.

* Conditions: Case temperature, max. +60 °C

General mechanical data	
Rotating speed, max.	500 rpm
Life, min.	5 x 10 ⁶ revolutions
Starting torque, max.	0.05 Nm @ room temperature
Torque during rotation, max.	0.05 Nm @ room temperature
Case material	copper alloy
Case surface finish	partially silver plated
Weight, approx.	0.028 kg

General environmental conditions	
Operation	
Ambient temperature range	-40 °C ... +70 °C
Relative humidity, max.	95%
IP protection level	IP40
Storage	
Ambient temperature range	-50 °C ... +70 °C
Relative humidity, max.	95%

SINGLE CHANNEL COAX ROTARY JOINT

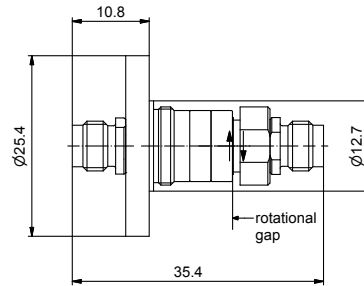
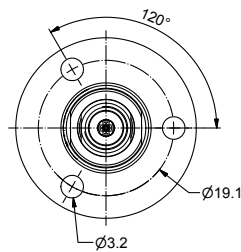

RF channel characteristics	BN 83 50 77
Interfaces	2.4 mm-f (50 Ω)
Style	I
Frequency range	DC - 50 GHz
Peak power, max.	15 kW*
Average power, max.	50 W @ 1 GHz 15 W @ 10 GHz 5 W @ 26.5 GHz 3 W @ 50 GHz
VSWR, max.	1.3 @ DC - 10 GHz 1.4 @ 10 - 26.5 GHz 1.7 @ 26.5 - 50 GHz
VSWR WOW, max.	0.05 @ DC - 26.5 GHz 0.10 @ 26.5 - 50 GHz
Insertion loss, max.	0.3 dB @ DC - 10 GHz 0.5 dB @ 10 - 26.5 GHz 0.9 dB @ 26.5 - 50 GHz
Insertion loss WOW, max.	0.05 @ DC - 26.5 GHz 0.10 @ 26.5 - 50 GHz
Phase WOW, max.	1.0 deg. @ DC - 26.5 GHz 2.0 deg. @ 26.5 - 50 GHz

* Conditions: Operating altitude if not pressurized, max. 2500 m

General mechanical data	
Rotating speed, max.	200 rpm
Life, min.	5 x 10 ⁶ revolutions
Starting torque, max.	0.05 Nm @ room temperature
Torque during rotation, max.	0.05 Nm @ room temperature
Case material	copper alloy
Case surface finish	partially silver plated
Weight, approx.	0.028 kg

General environmental conditions	
Operation	
Ambient temperature range	-40 °C ... +70 °C
Relative humidity, max.	95%
IP protection level	IP40
Storage	
Ambient temperature range	-50 °C ... +70 °C
Relative humidity, max.	95%

SINGLE CHANNEL COAX ROTARY JOINT

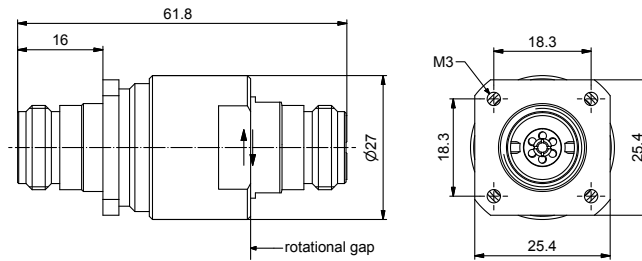

RF channel characteristics	BN 83 50 87
Interfaces	N-f (50 Ω)
Style	I
Frequency range	DC - 18 GHz
Peak power, max.	15 kW*
Average power, max.	200 W @ DC - 2 GHz 100 W @ 2 - 8 GHz 75 W @ 8 - 15 GHz 70 W @ 15 - 18 GHz
VSWR, max.	1.06 @ DC - 2 GHz 1.10 @ 2 - 8 GHz 1.15 @ 8 - 15 GHz 1.20 @ 15 - 18 GHz
VSWR WOW, max.	0.02
Insertion loss, max.	0.03 dB @ DC - 2 GHz 0.10 dB @ 2 - 8 GHz 0.15 dB @ 8 - 15 GHz 0.20 dB @ 15 - 18 GHz
Insertion loss WOW, max.	0.03 dB
Phase WOW, max.	2 deg.

* Conditions: Operating altitude if not pressurized, max. 2500 m

General mechanical data	
Rotating speed, max.	300 rpm
Life, min.	5 x 10 ⁶ revolutions
Starting torque, max.	0.3 Nm @ room temperature
Torque during rotation, max.	0.3 Nm @ room temperature
Case material	copper alloy
Case surface finish	nickel plated
Weight, approx.	0.14 kg

General environmental conditions	
Operation	
Ambient temperature range	-40 °C ... +60 °C
Relative humidity, max.	95%
IP protection level	IP54 / IP65 @ stationary part only
Storage	
Ambient temperature range	-50 °C ... +70 °C
Relative humidity, max.	95%

SINGLE CHANNEL COAX ROTARY JOINT

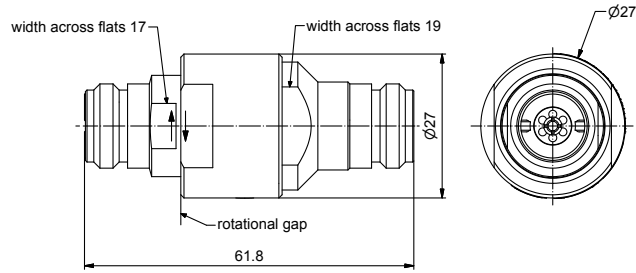

RF channel characteristics	BN 83 50 90
Interfaces	N-f (50 Ω)
Style	I
Frequency range	DC - 18 GHz
Peak power, max.	15 kW*
Average power, max.	200 W @ DC - 2 GHz 100 W @ 2 - 8 GHz 75 W @ 8 - 15 GHz 70 W @ 15 - 18 GHz
VSWR, max.	1.06 @ DC - 2 GHz 1.10 @ 2 - 8 GHz 1.15 @ 8 - 15 GHz 1.20 @ 15 - 18 GHz
VSWR WOW, max.	0.02
Insertion loss, max.	0.03 dB @ DC - 2 GHz 0.10 dB @ 2 - 8 GHz 0.15 dB @ 8 - 15 GHz 0.20 dB @ 15 - 18 GHz
Insertion loss WOW, max.	0.03 dB
Phase WOW, max.	2 deg.

* Conditions: Operating altitude if not pressurized, max. 2500 m

General mechanical data	
Rotating speed, max.	300 rpm
Life, min.	5 x 10 ⁶ revolutions
Starting torque, max.	0.3 Nm @ room temperature
Torque during rotation, max.	0.3 Nm @ room temperature
Case material	copper alloy
Case surface finish	nickel plated
Weight, approx.	0.14 kg

General environmental conditions	
Operation	
Ambient temperature range	-40 °C ... +60 °C
Relative humidity, max.	95%
IP protection level	IP65
Storage	
Ambient temperature range	-50 °C ... +70 °C
Relative humidity, max.	95%

SINGLE CHANNEL COAX ROTARY JOINT

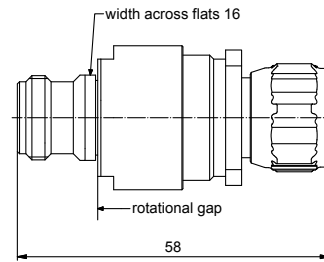
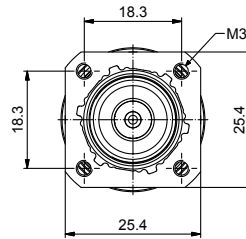

RF channel characteristics	BN 83 50 88
Interfaces	N-f (50 Ω) / N-m (50 Ω)
Style	I
Frequency range	DC - 8 GHz
Peak power, max.	5 kW
Average power, max.	50 W
VSWR, max.	1.10 @ DC - 2 GHz 1.15 @ 2 - 5 GHz 1.20 @ 5 - 8 GHz
VSWR WOW, max.	0.05
Insertion loss, max.	0.05 dB @ DC - 2 GHz 0.10 dB @ 2 - 5 GHz 0.15 dB @ 5 - 8 GHz
Insertion loss WOW, max.	0.05 dB
Phase WOW, max.	2 deg.

General mechanical data	
Rotating speed, max.	200 rpm
Life, min.	5 x 10 ⁶ revolutions
Starting torque, max.	0.1 Nm @ room temperature
Torque during rotation, max.	0.1 Nm @ room temperature
Case material	copper alloy
Case surface finish	Cu-Sn-Zn plated
Weight, approx.	0.14 kg

General environmental conditions	
Operation	
Ambient temperature range	-40 °C ... +65 °C
Relative humidity, max.	95%
IP protection level	IP41
Storage	
Ambient temperature range	-50 °C ... +70 °C
Relative humidity, max.	95%

SINGLE CHANNEL COAX ROTARY JOINT

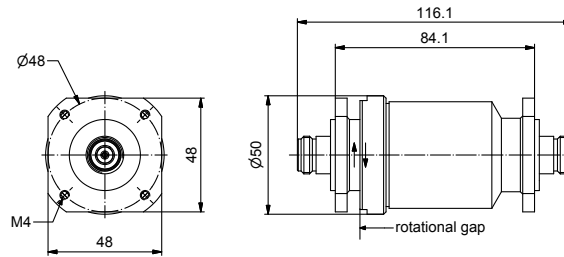

RF channel characteristics	BN 94 54 21
Interfaces	N-f (50 Ω)
Style	I
Frequency range	DC - 5 GHz
Peak power, max.	15 kW*
Average power, max.	1.0 KW @ 200 MHz 400 W @ 1 GHz 300 W @ 2 GHz
VSWR, max.	1.06 @ DC - 2.0 GHz 1.10 @ 2.0 - 4.0 GHz 1.15 @ 4.0 - 5.0 GHz
VSWR WOW, max.	0.012
Insertion loss, max.	0.2 dB
Insertion loss WOW, max.	0.05 dB
Phase WOW, max.	1 deg.

* Conditions: Operating altitude if not pressurized, max. 5000 m

General mechanical data	
Rotating speed, max.	100 rpm
Life, min.	5 x 10 ⁶ revolutions
Starting torque, max.	0.05 Nm @ room temperature
Torque during rotation, max.	0.05 Nm @ room temperature
Case material	copper alloy
Case surface finish	silver plated
Weight, approx.	1.0 kg

General environmental conditions	
Operation	
Ambient temperature range	-40 °C ... +70 °C
Relative humidity, max.	95%
IP protection level	IP65
Storage	
Ambient temperature range	-40 °C ... +70 °C
Relative humidity, max.	95%

SINGLE CHANNEL COAX ROTARY JOINT

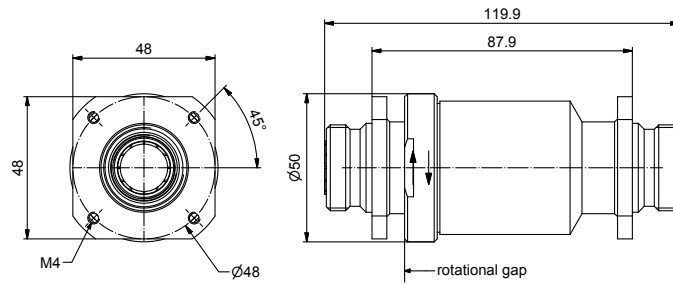

RF channel characteristics	BN 94 54 36
Interfaces	7-16-f (50 Ω)
Style	I
Frequency range	DC - 5 GHz
Peak power, max.	10 kW
Average power, max.	600 W
VSWR, max.	1.1 @ DC - 5 GHz
VSWR WOW, max.	0.006
Insertion loss, max.	0.2 dB @ DC - 5 GHz
Insertion loss WOW, max.	0.02 dB

General mechanical data	
Rotating speed, max.	200 rpm
Life, min.	10 x 10 ⁶ revolutions
Starting torque, max.	0.1 Nm @ room temperature
Torque during rotation, max.	0.1 Nm @ room temperature
Case material	copper alloy
Case surface finish	silver plated
Weight, approx.	1.0 kg

General environmental conditions	
Operation	
Ambient temperature range	-40 °C ... +85 °C
Relative humidity, max.	95%
IP protection level	IP64
Storage	
Ambient temperature range	-40 °C ... +85 °C
Relative humidity, max.	95%

SINGLE CHANNEL COAX ROTARY JOINT

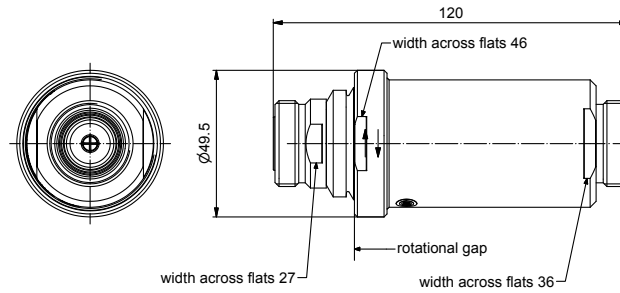

RF channel characteristics	BN 94 54 20
Interfaces	7-16 (50 Ω)
Style	I
Frequency range	2.8 - 3.4 GHz
Peak power, max.	50 kW
Average power, max.	500 W
VSWR, max.	1.06
VSWR WOW, max.	0.005
Insertion loss, max.	0.1 dB
Insertion loss WOW, max.	0.01 dB
Phase WOW, max.	1 deg.

General mechanical data	
Rotating speed, max.	60 rpm
Life, min.	100 x 10 ⁶ revolutions
Starting torque, max.	0.65 Nm @ room temperature
Torque during rotation, max.	0.5 Nm @ room temperature
Case material	copper alloy
Case surface finish, per MIL-C-5541	chromate conversion coat
Weight, approx.	0.9 kg

General environmental conditions	
Operation	
Ambient temperature range	-25 °C ... +85 °C
Relative humidity, max.	95%
IP protection level	IP53
Storage	
Ambient temperature range	-40 °C ... +85 °C
Relative humidity, max.	95%

SINGLE CHANNEL COAX ROTARY JOINT

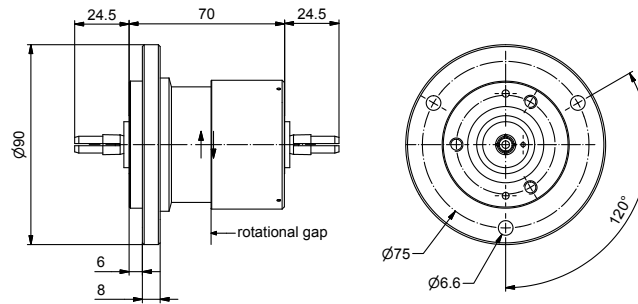

RF channel characteristics	BN 82 10 03
Interfaces	7/8" EIA (50 Ω)
Style	I
Frequency range	DC - 4 GHz
Peak power, max.	50 kW @ 200 MHz
Average power, max.	4.5 kW @ 200 MHz
VSWR, max.	1.12
VSWR WOW, max.	0.01
Insertion loss, max.	0.10 dB
Insertion loss WOW, max.	0.02 dB
Phase WOW, max.	1 deg.

General mechanical data	
Rotating speed, max.	200 rpm
Life, min.	5 x 10 ⁶ revolutions
Starting torque, max.	1 Nm @ room temperature
Torque during rotation, max.	1 Nm @ room temperature
Case material	copper alloy
Case surface finish	painting (RAL 7001)
Weight, approx.	2.0 kg

General environmental conditions	
Operation	
Ambient temperature range	-40 °C ... +60 °C
Relative humidity, max.	95%
IP protection level	IP64
Storage	
Ambient temperature range	-50 °C ... +70 °C
Relative humidity, max.	95%

SINGLE CHANNEL COAX ROTARY JOINT

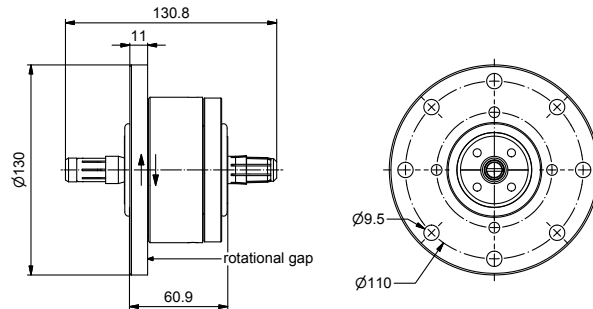

RF channel characteristics	BN 84 06 01
Interfaces	1 5/8" EIA (50 Ω) with fixed coupling elements
Style	I
Frequency range	DC - 2.8 GHz
Peak power, max.	70 kW @ 200 MHz 30 kW @ 1 GHz 22 kW @ 2 GHz 18 kW @ 2.8 GHz
Average power, max.	10.0 kW @ 200 MHz 4.5 kW @ 1 GHz 3.0 kW @ 2 GHz 2.5 kW @ 2.8 GHz
VSWR, max.	1.06
VSWR WOW, max.	0.01
Insertion loss, max.	0.2 dB
Insertion loss WOW, max.	0.02 dB
Phase WOW, max.	1 deg.

General mechanical data	
Rotating speed, max.	60 rpm
Life, min.	1.5 x 10 ⁶ revolutions
Starting torque, max.	2 Nm @ room temperature
Torque during rotation, max.	1 Nm @ room temperature
Case material	copper alloy
Case surface finish	painted grey RAL 7001
Connector material	copper alloy
Connector surface finish	silver plated
Weight, approx.	2.8 kg

General environmental conditions	
Operation	
Ambient temperature range	-40 °C ... +60 °C
Relative humidity, max.	95%
IP protection level	IP64
Storage	
Ambient temperature range	-50 °C ... +70 °C
Relative humidity, max.	95%



DUAL CHANNEL COAX ROTARY JOINTS

Our standard dual channel rotary joint portfolio is designed for use in military and SatCom applications. Being technically superior we offer combinations up to 50 GHz. Therefore many applications can benefit of this compact design suitable for airborne, land and marine applications. On the following pages we present a wide range of designs. Customised designs are available on request.

Part number	Number of channel	Frequency range main channel	Interface	Page
BN 15 31 89	2	DC - 18 GHz	SMA-f (50 Ω)	48
BN 15 31 33	2	DC - 18 GHz	SMA-f (50 Ω)	49
BN 15 31 67	2	DC - 4.5 GHz	3.5 mm-f (50 Ω)	50
BN 15 31 27	2	DC - 4.5 GHz	3.5 mm-f (50 Ω)	51
BN 15 31 64	2	DC - 4.5 GHz	3.5 mm-f (50 Ω)	52
BN 15 31 68	2	DC - 8 GHz	3.5 mm-f (50 Ω)	53
BN 15 31 71	2	DC - 8 GHz	3.5 mm-f (50 Ω)	54
BN 15 31 46	2	DC - 14.5 GHz	3.5 mm-f (50 Ω)	55
BN 15 31 66	2	DC - 4.5 GHz	SMA (50 Ω)	56
BN 15 31 39	2	DC - 18 GHz	3.5 mm-f (50 Ω)	57
BN 15 31 06	2	DC - 16 GHz	3.5 mm-f (50 Ω)	58
BN 15 31 07	2	DC - 16 GHz	3.5 mm-f (50 Ω)	59
BN 15 31 18	2	DC - 18 GHz	3.5 mm-f (50 Ω)	60
BN 15 31 92	2	DC - 18 GHz	3.5 mm-f (50 Ω)	61
BN 15 31 58	2	DC - 50 GHz	2.4 mm-f (50 Ω)	62
BN 15 31 50	2	0.9 - 1.2 GHz	N-f (50 Ω)	63
BN 15 31 51	2	13.75 - 14.5 GHz	N-f (50 Ω)	64
BN 15 31 30	2	19.7 - 21.2 GHz	2.92 mm-f (50 Ω)	65



DUAL CHANNEL COAX ROTARY JOINT

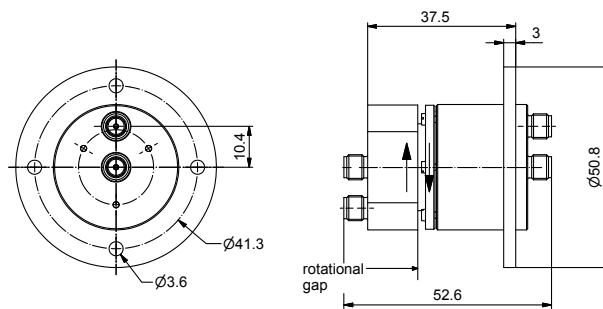

RF channel characteristics	BN 15 31 89	
Channel designation	Channel 1	Channel 2
Interfaces	SMA-f (50 Ω)	SMA-f (50 Ω)
Style	I	I
Frequency range	DC - 18 GHz	DC - 4 GHz
Peak power, max.	3 kW @ sea level 1.5 kW @ operating altitude: 3000m	3 kW @ sea level 1.5 kW @ operating altitude: 3000m
Average power, max.	200 W @ 1 GHz	200 W @ 1 GHz
VSWR, max.	1.2 @ DC - 4 GHz 1.5 @ 4 - 18 GHz	1.2 @ DC - 1.4 GHz 1.4 @ 1.4 - 2 GHz 1.8 @ 2 - 3 GHz 2.5 @ 3 - 4 GHz
VSWR WOW, max.	0.05	0.1 @ DC - 2 GHz 0.4 @ 2 - 4 GHz
Insertion loss, max.	0.1 @ DC - 4 GHz 0.5 @ 4 - 18 GHz	0.5 @ DC - 2 GHz 1.0 @ 2 - 4 GHz
Insertion loss WOW, max.	0.05 dB	0.1 @ DC - 2 GHz 0.3 @ 2 - 4 GHz
Phase WOW, max.	1 deg. @ DC - 18 GHz	1 deg. @ DC - 1.1 GHz 2 deg. @ 1.1 - 4 GHz
Isolation, min.	70 dB @ DC - 4 GHz	
DC carrying capability, max. (DC applied to one channel only)	0.5 A, 48 VDC @ full RF avg. power 2.0 A, 48 VDC @ RF avg. power 5 W 5.0 A*, 48 VDC @ RF avg. power 5 W	0.5 A, 24 VDC @ full RF avg. power

* Conditions: applied for max. 1 x 10⁶ revolutions

General mechanical data	
Rotating speed, max.	60 rpm
Life, min.	5 x 10 ⁶ revolutions
Starting torque, max.	0.05 Nm @ room temperature
Torque during rotation, max.	0.05 Nm @ room temperature
Case material	aluminum alloy
Case surface finish	chromate conversion coat
Weight, approx.	0.15 kg

General environmental conditions	
Operation	
Ambient temperature range	-40 °C ... +70 °C
Relative humidity, max.	95%
IP protection level	IP50
Storage	
Ambient temperature range	-50 °C ... +70 °C
Relative humidity, max.	95%

DUAL CHANNEL COAX ROTARY JOINT

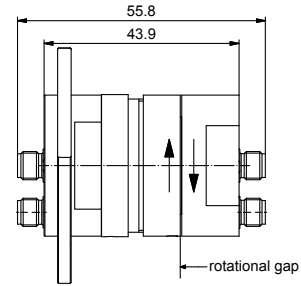
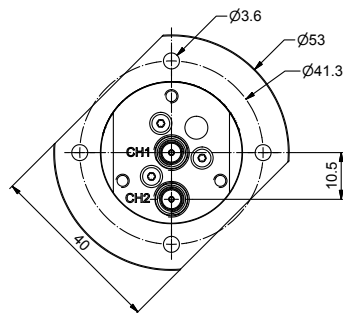
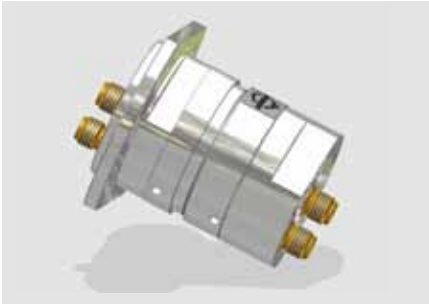

RF channel characteristics	BN 15 31 33	
Channel designation	Channel 1	Channel 2
Interfaces	SMA-f (50 Ω)	SMA-f (50 Ω)
Style	I	I
Frequency range	DC - 18 GHz	DC - 13 GHz
Peak power, max.	1 kW	1 kW
Average power, max.	100 W @ DC to 2 GHz 60 W @ 2 to 4 GHz 35 W @ 4 to 8 GHz 25 W @ 8 to 12 GHz 17 W @ 12 to 18 GHz	10 W
VSWR, max.	1.35 @ DC to 8 GHz 1.5 @ 8 to 18 GHz	2.0
VSWR WOW, max.	0.1	0.5
Insertion loss, max.	0.4 dB @ DC to 8 GHz 1.0 dB @ 8 to 18 GHz	1.0 dB
Insertion loss WOW, max.	0.06 dB	0.04 dB
Phase WOW, max.	0.5 deg. @ DC to 8 GHz 1.0 deg. @ 8 to 18 GHz	4 deg. @ DC to 8 GHz 10 deg. @ 8 to 13 GHz
Isolation, min.	50 dB	
DC carrying capability, max. (DC applied to one channel only)	0.5 A, 48 VDC @ full RF avg. power 2.0 A, 48 VDC @ RF avg. power 5 W 5.0 A*, 48 VDC @ RF avg. power 5 W	0.5 A, 24 VDC @ full RF avg. power

* Conditions: applied for max. 1 x 10⁶ revolutions

General mechanical data	
Rotating speed, max.	30 rpm
Life, min.	5 x 10 ⁶ revolutions
Starting torque, max.	0.05 Nm @ room temperature
Torque during rotation, max.	0.05 Nm @ room temperature
Case material	aluminum alloy
Case surface finish	chromate conversion coat
Weight, approx.	0.13 kg

General environmental conditions	
Operation	
Ambient temperature range	-40 °C ... +70 °C
Relative humidity, max.	95%
IP protection level	IP60
Storage	
Ambient temperature range	-50 °C ... +70 °C
Relative humidity, max.	95%

DUAL CHANNEL COAX ROTARY JOINT

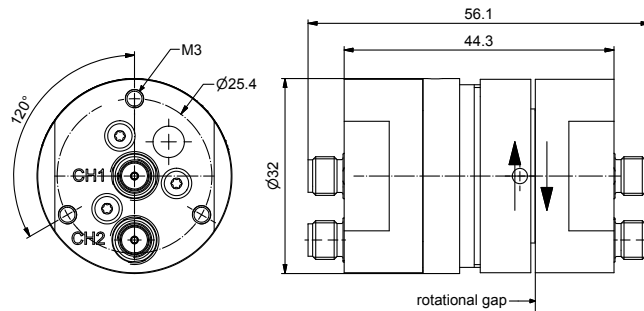

RF channel characteristics	BN 15 31 67	
Channel designation	Channel 1	Channel 2
Interfaces	3.5 mm-f (50 Ω)	3.5 mm-f (50 Ω)
Style	I	I
Frequency range	DC - 4.5 GHz	DC - 4.5 GHz
Peak power, max.	1 kW	1 kW
Average power, max.	100 W @ DC - 2 GHz 60 W @ 2 - 4.5 GHz	10 W
VSWR, max.	1.2	1.5
VSWR WOW, max.	0.05	0.2
Insertion loss, max.	0.25 dB	0.30 dB
Insertion loss WOW, max.	0.05 dB	0.15 dB
Phase WOW, max.	0.5 deg.	4 deg.
Isolation, min.	50 dB	
DC carrying capability, max. (DC applied to one channel only)	0.5 A, 48 VDC @ full RF avg. power 2.0 A, 48 VDC @ RF avg. power 5 W 5.0 A*, 48 VDC @ RF avg. power 5 W	0.5 A, 24 VDC @ full RF avg. power

* Conditions: applied for max. 1 x 10⁶ revolutions

General mechanical data	
Rotating speed, max.	30 rpm (other rpm on request)
Life, min.	5 x 10 ⁶ revolutions
Starting torque, max.	0.05 Nm @ room temperature
Torque during rotation, max.	0.05 Nm @ room temperature
Case material	aluminum alloy
Case surface finish, per MIL-C-5541	chromate conversion coat
Weight, approx.	0.13 kg

General environmental conditions	
Operation	
Ambient temperature range	-40 °C ... +70 °C
Relative humidity, max.	95%
IP protection level	IP60
Storage	
Ambient temperature range	-55 °C ... +70 °C
Relative humidity, max.	95%

DUAL CHANNEL COAX ROTARY JOINT

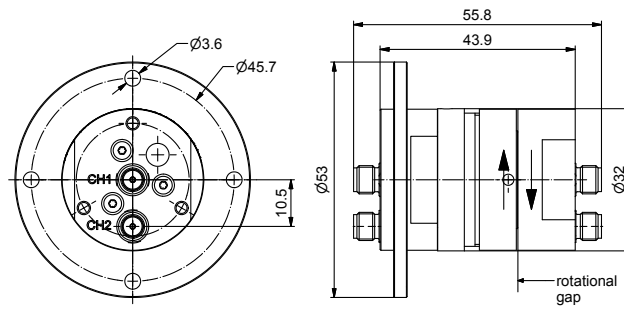

RF channel characteristics	BN 15 31 27	
Channel designation	Channel 1	Channel 2
Interfaces	3.5 mm-f (50 Ω)	3.5 mm-f (50 Ω)
Style	I	I
Frequency range	DC - 4.5 GHz	DC - 4.5 GHz
Peak power, max.	1 kW	1 kW
Average power, max.	100 W @ DC - 2 GHz 60 W @ 2 - 4.5 GHz	10 W
VSWR, max.	1.2	1.5
VSWR WOW, max.	0.05	0.2
Insertion loss, max.	0.25 dB	0.30 dB
Insertion loss WOW, max.	0.05 dB	0.15 dB
Phase WOW, max.	0.5 deg.	4 deg.
Isolation, min.	50 dB	
DC carrying capability, max. (DC applied to one channel only)	0.5 A, 48 VDC @ full RF avg. power 2.0 A, 48 VDC @ RF avg. power 5 W 5.0 A*, 48 VDC @ RF avg. power 5 W	0.5 A, 24 VDC @ full RF avg. power

* Conditions: applied for max. 1 x 10⁶ revolutions

General mechanical data	
Rotating speed, max.	30 rpm
Life, min.	5 x 10 ⁶ revolutions
Starting torque, max.	0.05 Nm @ room temperature
Torque during rotation, max.	0.05 Nm @ room temperature
Case material	aluminum alloy
Case surface finish, per MIL-C-5541	chromate conversion coat
Weight, approx.	0.13 kg

General environmental conditions	
Operation	
Ambient temperature range	-40 °C ... +70 °C
Relative humidity, max.	95%
IP protection level	IP60
Storage	
Ambient temperature range	-55 °C ... +70 °C
Relative humidity, max.	95%

DUAL CHANNEL COAX ROTARY JOINT

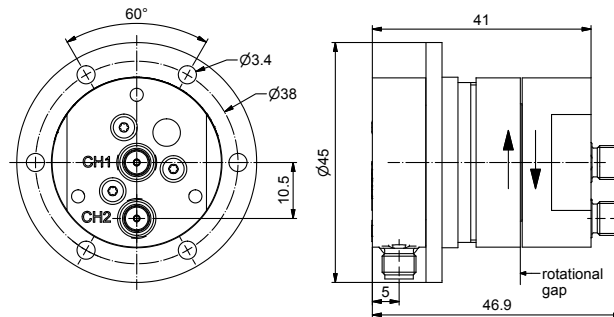

RF channel characteristics	BN 15 31 64	
Channel designation	Channel 1	Channel 2
Interfaces	3.5 mm-f (50 Ω)	3.5 mm-f (50 Ω)
Style	L with corpus interfaces sidewise	L with corpus interfaces sidewise
Frequency range	DC - 4.5 GHz	DC - 4.5 GHz
Peak power, max.	1 kW	1 kW
Average power, max.	100 W @ DC - 2 GHz 60 W @ 2 - 4.5 GHz	10 W
VSWR, max.	1.5	1.5
VSWR WOW, max.	0.1	0.5
Insertion loss, max.	0.3 dB	0.3 dB
Insertion loss WOW, max.	0.15 dB	0.15 dB
Isolation, min.	50 dB	
DC carrying capability, max. (DC applied to one channel only)	0.5 A, 48 VDC @ full RF avg. power 2.0 A, 48 VDC @ RF avg. power 5 W 5.0 A*, 48 VDC @ RF avg. power 5 W	0.5 A, 24 VDC @ full RF avg. power

* Conditions: applied for max. 1 x 10⁶ revolutions

General mechanical data	
Rotating speed, max.	30 rpm
Life, min.	5 x 10 ⁶ revolutions
Starting torque, max.	0.05 Nm @ room temperature
Torque during rotation, max.	0.05 Nm @ room temperature
Case material	aluminum alloy
Case surface finish, per MIL-C-5541	chromate conversion coat
Weight, approx.	0.13 kg

General environmental conditions	
Operation	
Ambient temperature range	-40 °C ... +70 °C
Relative humidity, max.	95%
IP protection level	IP60
Storage	
Ambient temperature range	-55 °C ... +70 °C
Relative humidity, max.	95%

DUAL CHANNEL COAX ROTARY JOINT

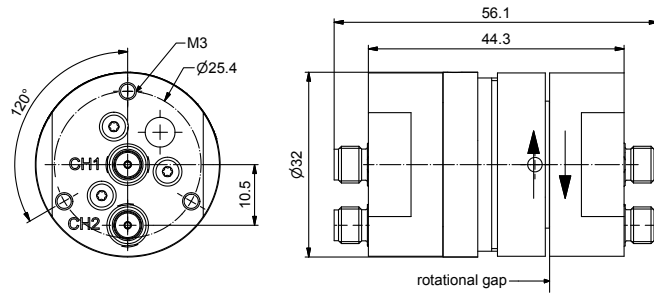

RF channel characteristics	BN 15 31 68	
Channel designation	Channel 1	Channel 2
Interfaces	3.5 mm-f (50 Ω)	3.5 mm-f (50 Ω)
Style	I	I
Frequency range	DC - 8 GHz	DC - 8 GHz
Peak power, max.	1 kW	1 kW
Average power, max.	100 W @ DC to 2 GHz 60 W @ 2 to 4 GHz 35 W @ 4 to 8 GHz	10 W
VSWR, max.	1.35 @ DC to 8 GHz	2.0 @ DC to 4 GHz 2.5 @ 4 to 8 GHz
VSWR WOW, max.	0.1	0.1 @ DC to 4 GHz 0.4 @ 4 to 8 GHz
Insertion loss, max.	0.4 dB	0.5 dB @ DC to 4 GHz 1.0 dB @ 4 to 8 GHz
Insertion loss WOW, max.	0.06 dB	0.10 dB @ DC to 4 GHz 0.35 dB @ 4 to 8 GHz
Phase WOW, max.	0.5 deg.	4 deg.
Isolation, min.	50 dB	
DC carrying capability, max. (DC applied to one channel only)	0.5 A, 48 VDC @ full RF avg. power 2.0 A, 48 VDC @ RF avg. power 5 W 5.0 A*, 48 VDC @ RF avg. power 5 W	0.5 A, 24 VDC @ full RF avg. power

* Conditions: applied for max. 1 x 10⁶ revolutions

General mechanical data	
Rotating speed, max.	30 rpm
Life, min.	5 x 10 ⁶ revolutions
Starting torque, max.	0.05 Nm @ room temperature
Torque during rotation, max.	0.05 Nm @ room temperature
Case material	aluminum alloy
Case surface finish, per MIL-C-5541	chromate conversion coat
Weight, approx.	0.13 kg
General environmental conditions	
Operation	
Ambient temperature range	-40 °C ... +70 °C
Relative humidity, max.	95%
IP protection level	IP60
Storage	
Ambient temperature range	-55 °C ... +70 °C
Relative humidity, max.	95%

DUAL CHANNEL COAX ROTARY JOINT

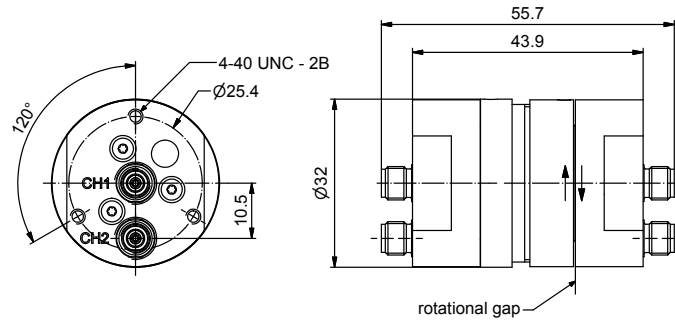

RF channel characteristics	BN 15 31 71	
Channel designation	Channel 1	Channel 2
Interfaces	3.5 mm-f (50 Ω)	3.5 mm-f (50 Ω)
Style	I	I
Frequency range	DC - 8 GHz	DC - 8 GHz
Peak power, max.	1 kW	1 kW
Average power, max.	100 W @ DC - 2 GHz 60 W @ 2 - 4 GHz 35 W @ 4 - 8 GHz	10 W
VSWR, max.	1.20 @ DC - 4.5 GHz 1.35 @ 4.5 - 8 GHz	1.5 @ DC - 4.5 GHz 2.5 @ 4.5 - 8 GHz
VSWR WOW, max.	0.05 @ DC - 4.5 GHz 0.10 @ 4.5 - 8 GHz	0.2 @ DC - 4.5 GHz 0.4 @ 4.5 - 8 GHz
Insertion loss, max.	0.25 @ DC - 4.5 GHz 0.40 @ 4.5 - 8 GHz	0.3 @ DC - 4.5 GHz 1.0 @ 4.5 - 8 GHz
Insertion loss WOW, max.	0.05 @ DC - 8 GHz	0.15 @ DC - 4.5 GHz 0.35 @ 4.5 - 8 GHz
Phase WOW, max.	0.5 deg.	4 deg.
Isolation, min.	50 dB	
DC carrying capability, max. (DC applied to one channel only)	0.5 A, 48 VDC @ full RF avg. power 2.0 A, 48 VDC @ RF avg. power 5 W 5.0 A*, 48 VDC @ RF avg. power 5 W	0.5 A, 24 VDC @ full RF avg. power

* Conditions: applied for max. 1 x 10⁶ revolutions

General mechanical data	
Rotating speed, max.	30 rpm
Life, min.	5 x 10 ⁶ revolutions
Starting torque, max.	0.05 Nm @ room temperature
Torque during rotation, max.	0.05 Nm @ room temperature
Case material	aluminum alloy
Case surface finish, per MIL-C-5541	chromate conversion coat
Weight, approx.	0.13 kg
General environmental conditions	
Operation	
Ambient temperature range	-40 °C ... +70 °C
Relative humidity, max.	95%
IP protection level	IP60
Storage	
Ambient temperature range	-55 °C ... +70 °C
Relative humidity, max.	95%

DUAL CHANNEL COAX ROTARY JOINT

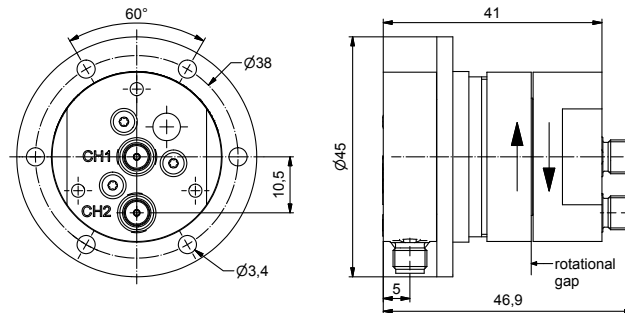

RF channel characteristics	BN 15 31 46	
Channel designation	Channel 1	Channel 2
Interfaces	3.5 mm-f (50 Ω)	3.5 mm-f (50 Ω)
Style	L	L
Frequency range	DC - 14.5 GHz	DC - 13 GHz
Peak power, max.	1 kW	1 kW
Average power, max.	100 W @ DC - 2 GHz 60 W @ 2 - 4 GHz 35 W @ 4 - 8 GHz 25 W @ 8 - 12 GHz 17 W @ 12 - 14.5 GHz	10 W
VSWR, max.	1.50	2.0
VSWR WOW, max.	0.1	0.5
Insertion loss, max.	1.0 dB	1.0 dB
Insertion loss WOW, max.	0.06 dB	0.4 dB
Phase WOW, max.	0.5 deg. @ DC - 8 GHz 1.0 deg. @ 8 - 14.5 GHz	4 deg. @ DC - 8 GHz 10 deg. @ 8 - 13 GHz
Isolation, min.	50 dB	
DC carrying capability, max. (DC applied to one channel only)	0.5 A, 48 VDC @ full RF avg. power 2.0 A, 48 VDC @ RF avg. power 5 W 5.0 A*, 48 VDC @ RF avg. power 5 W	0.5 A, 24 VDC @ full RF avg. power

* Conditions: applied for max. 1 x 10⁶ revolutions

General mechanical data	
Rotating speed, max.	30 rpm
Life, min.	5 x 10 ⁶ revolutions
Starting torque, max.	0.05 Nm @ room temperature
Torque during rotation, max.	0.05 Nm @ room temperature
Case material	aluminum alloy
Case surface finish	chromate conversion coat
Weight, approx.	0.13 kg
General environmental conditions	
Operation	
Ambient temperature range	-40 °C ... +70 °C
Relative humidity, max.	95%
IP protection level	IP60
Storage	
Ambient temperature range	-55 °C ... +70 °C
Relative humidity, max.	95%

DUAL CHANNEL COAX ROTARY JOINT

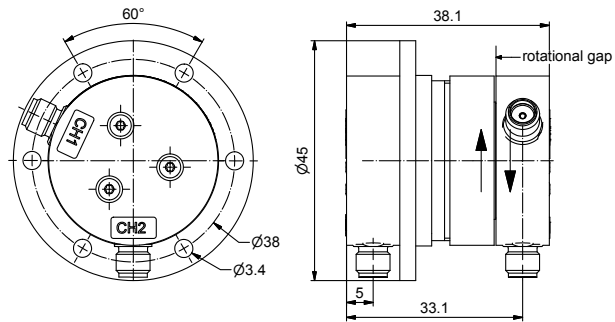

RF channel characteristics	BN 15 31 66	
Channel designation	Channel 1	Channel 2
Interfaces	SMA (50 Ω)	SMA (50 Ω)
Style	U	U
Frequency range	DC - 4.5 GHz	DC - 4.5 GHz
Peak power, max.	1 kW	1 kW
Average power, max.	100 W @ DC - 2 GHz 60 W @ 2 - 4.5 GHz	10 W
VSWR, max.	1.50	2.0
VSWR WOW, max.	0.1	0.5
Insertion loss, max.	1.0 dB	1.0 dB
Insertion loss WOW, max.	0.06 dB	0.4 dB
Phase WOW, max.	0.5 deg. @ DC - 4.5 GHz	4.0 deg. @ DC - 4.5 GHz
Isolation, min.	50 dB	
DC carrying capability, max. (DC applied to one channel only)	0.5 A, 48 VDC @ full RF avg. power 2.0 A, 48 VDC @ RF avg. power 5 W 5.0 A*, 48 VDC @ RF avg. power 5 W	0.5 A, 24 VDC @ full RF avg. power

* Conditions: applied for max. 1 x 10⁶ revolutions

General mechanical data	
Rotating speed, max.	30 rpm
Life, min.	5 x 10 ⁶ revolutions
Starting torque, max.	0.05 Nm @ room temperature
Torque during rotation, max.	0.05 Nm @ room temperature
Case material	aluminum alloy
Case surface finish, per MIL-C-5541	chromate conversion coat
Weight, approx.	0.13 kg
General environmental conditions	
Operation	
Ambient temperature range	-40 °C ... +70 °C
Relative humidity, max.	95%
IP protection level	IP60
Storage	
Ambient temperature range	-55 °C ... +70 °C
Relative humidity, max.	95%

DUAL CHANNEL COAX ROTARY JOINT

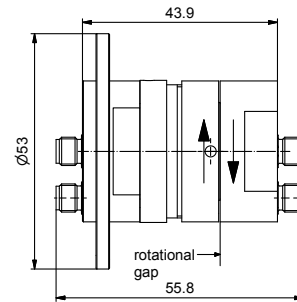
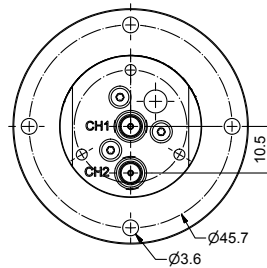

RF channel characteristics	BN 15 31 39	
Channel designation	Channel 1	Channel 2
Interfaces	3.5 mm-f (50 Ω)	3.5 mm-f (50 Ω)
Style	I	I
Frequency range	DC - 18 GHz	DC - 13 GHz
Peak power, max.	1 kW	1 kW
Average power, max.	100 W @ DC - 2 GHz 60 W @ 2 - 4 GHz 35 W @ 4 - 8 GHz 25 W @ 8 - 12 GHz 17 W @ 12 - 18 GHz	10 W
VSWR, max.	1.35 @ DC - 8 GHz 1.50 @ 8 - 18 GHz	2.0
VSWR WOW, max.	0.1	0.5
Insertion loss, max.	0.4 dB @ DC - 8 GHz 1.0 dB @ 8 - 18 GHz	1.0 dB
Insertion loss WOW, max.	0.06 dB	0.4 dB
Phase WOW, max.	0.5 deg. @ DC - 8 GHz 1.0 deg. @ 8 - 18 GHz	4 deg. @ DC - 8 GHz 10 deg. @ 8 - 13 GHz
Isolation, min.	50 dB	
DC carrying capability, max. (DC applied to one channel only)	0.5 A, 48 VDC @ full RF avg. power 2.0 A, 48 VDC @ RF avg. power 5 W 5.0 A*, 48 VDC @ RF avg. power 5 W	0.5 A, 24 VDC @ full RF avg. power

* Conditions: applied for max. 1 x 10⁶ revolutions

General mechanical data	
Rotating speed, max.	30 rpm
Life, min.	5 x 10 ⁶ revolutions
Starting torque, max.	0.05 Nm @ room temperature
Torque during rotation, max.	0.05 Nm @ room temperature
Case material	aluminum alloy
Case surface finish	chromate conversion coat
Weight, approx.	0.13 kg
General environmental conditions	
Operation	
Ambient temperature range	-40 °C ... +70 °C
Relative humidity, max.	95%
IP protection level	IP60
Storage	
Ambient temperature range	-55 °C ... +70 °C
Relative humidity, max.	95%

DUAL CHANNEL COAX ROTARY JOINT

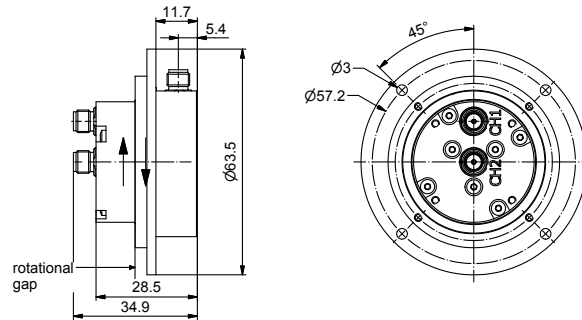

RF channel characteristics	BN 15 31 06	
Channel designation	Channel 1	Channel 2
Interfaces	3.5 mm-f (50 Ω)	3.5 mm-f (50 Ω)
Style	L	L
Frequency range	DC - 13 GHz	DC - 16 GHz
Peak power, max.	1 kW	1 kW
Average power, max.	10 W	100 W @ DC - 2 GHz 60 W @ 2 - 4 GHz 35 W @ 4 - 8 GHz 25 W @ 8 - 12 GHz 17 W @ 12 - 16 GHz
VSWR, max.	1.4 @ DC - 5 GHz 1.9 @ 5 - 13 GHz	1.3 @ DC - 6 GHz 1.4 @ 6 - 12 GHz 1.6 @ 12 - 16 GHz
VSWR WOW, max.	0.5	0.1
Insertion loss, max.	0.5 dB @ DC - 5 GHz 0.7 dB @ 5 - 10 GHz 0.6 dB @ 10 - 13 GHz	0.3 dB @ DC - 6 GHz 0.6 dB @ 6 - 16 GHz
Insertion loss WOW, max.	0.3 dB	0.06 dB
Phase WOW, max.	4 deg. @ DC to 8 GHz 10 deg. @ 8 to 13 GHz	0.5 deg. @ DC to 8 GHz 1.0 deg. @ 8 to 16 GHz
Isolation, min.	50 dB	
DC carrying capability, max. (DC applied to one channel only)	0.5 A, 24 VDC @ full RF avg. power	0.5 A, 48 VDC @ full RF avg. power 2.0 A, 48 VDC @ RF avg. power 5 W 5.0 A*, 48 VDC @ RF avg. power 5 W

* Conditions: applied for max. 1 x 10⁶ revolutions

General mechanical data	
Rotating speed, max.	60 rpm
Life, min.	5 x 10 ⁶ revolutions
Starting torque, max.	0.45 Nm @ room temperature
Torque during rotation, max.	0.45 Nm @ room temperature
Case material	aluminum alloy
Case surface finish, per MIL-C-5541	chromate conversion coat
Weight, approx.	0.14 kg

General environmental conditions	
Operation	
Ambient temperature range	-55 °C ... +70 °C
Relative humidity, max.	95%
IP protection level	IP65
Storage	
Ambient temperature range	-55 °C ... +85 °C
Relative humidity, max.	95%

DUAL CHANNEL COAX ROTARY JOINT

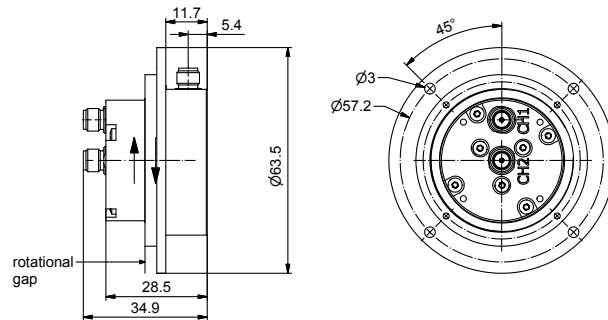

RF channel characteristics	BN 15 31 07	
Channel designation	Channel 1	Channel 2
Interfaces	3.5 mm-f (50 Ω)	3.5 mm-f (50 Ω)
Style	L	L
Frequency range	DC - 13 GHz	DC - 16 GHz
Peak power, max.	1 kW	1 kW
Average power, max.	10 W	100 W @ DC - 2 GHz 60 W @ 2 - 4 GHz 35 W @ 4 - 8 GHz 25 W @ 8 - 12 GHz 17 W @ 12 - 16 GHz
VSWR, max.	1.4 @ DC - 5 GHz 1.9 @ 5 - 13 GHz	1.3 @ DC - 6 GHz 1.4 @ 6 - 12 GHz 1.6 @ 12 - 16 GHz
VSWR WOW, max.	0.5	0.1
Insertion loss, max.	0.5 dB @ DC - 5 GHz 0.7 dB @ 5 - 10 GHz 0.6 dB @ 10 - 13 GHz	0.3 dB @ DC - 6 GHz 0.6 dB @ 6 - 16 GHz
Insertion loss WOW, max.	0.3 dB	0.06 dB
Phase WOW, max.	4 deg. @ DC - 8 GHz 10 deg. @ 8 - 13 GHz	0.5 deg. @ DC - 8 GHz 1.0 deg. @ 8 - 16 GHz
Isolation, min.	50 dB	
DC carrying capability, max. (DC applied to one channel only)	0.5 A, 24 VDC @ full RF avg. power	0.5 A, 48 VDC @ full RF avg. power 2.0 A, 48 VDC @ RF avg. power 5 W 5.0 A*, 48 VDC @ RF avg. power 5 W

* Conditions: applied for max. 1 x 10⁶ revolutions

General mechanical data	
Rotating speed, max.	60 rpm
Life, min.	5 x 10 ⁶ revolutions
Starting torque, max.	0.08 Nm @ room temperature
Torque during rotation, max.	0.05 Nm @ room temperature
Case material	aluminum alloy
Case surface finish, per MIL-C-5541	chromate conversion coat
Weight, approx.	0.13 kg

General environmental conditions	
Operation	
Ambient temperature range	-55 °C ... +70 °C
Relative humidity, max.	95%
IP protection level	IP51
Storage	
Ambient temperature range	-55 °C ... +85 °C
Relative humidity, max.	95%

DUAL CHANNEL COAX ROTARY JOINT

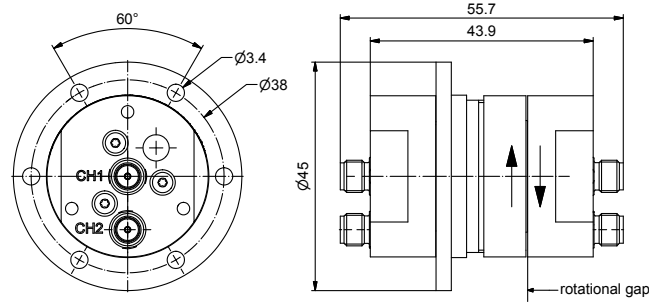

RF channel characteristics	BN 15 31 18	
Channel designation	Channel 1	Channel 2
Interfaces	3.5 mm-f (50 Ω)	3.5 mm-f (50 Ω)
Style	I	I
Frequency range	DC - 18 GHz	DC - 18 GHz
Peak power, max.	1 kW	1 kW
Average power, max.	100 W @ DC - 2 GHz 60 W @ 2 - 4 GHz 35 W @ 4 - 8 GHz 25 W @ 8 - 12 GHz 17 W @ 12 - 18 GHz	10 W
VSWR, max.	1.35 @ DC - 8 GHz 1.50 @ 8 - 18 GHz	2.0 @ DC - 4 GHz 2.5 @ 4 - 8 GHz 3.5 @ 8 - 12 GHz 4.5 @ 12 - 18 GHz
VSWR WOW, max.	0.1	0.1 @ DC - 4 GHz 0.4 @ 4 - 8 GHz 0.8 @ 8 - 12 GHz 2.0 @ 12 - 18 GHz
Insertion loss, max.	0.4 dB @ DC - 8 GHz 1.0 dB @ 8 - 18 GHz	0.5 dB @ DC - 4 GHz 1.0 dB @ 4 - 8 GHz 2.0 dB @ 8 - 12 GHz 3.5 dB @ 12 - 18 GHz
Insertion loss WOW, max.	0.06 dB	0.10 dB @ DC - 4 GHz 0.35 dB @ 4 - 8 GHz 0.70 dB @ 8 - 12 GHz 1.50 dB @ 12 to 18 GHz
Phase WOW, max.	0.5 deg. @ DC - 8 GHz 1.0 deg. @ 8 - 18 GHz	4 deg. @ DC - 8 GHz 10 deg. @ 8 - 12 GHz 25 deg. @ 12 - 18 GHz
Isolation, min.	50 dB	
DC carrying capability, max. (DC applied to one channel only)	0.5 A, 48 VDC @ full RF avg. power 2.0 A, 48 VDC @ RF avg. power 5 W 5.0 A*, 48 VDC @ RF avg. power 5 W	0.5 A, 24 VDC @ full RF avg. power

* Conditions: applied for max. 1 x 10⁶ revolutions

General mechanical data	
Rotating speed, max.	30 rpm
Life, min.	5 x 10 ⁶ revolutions
Starting torque, max.	0.05 Nm @ room temperature
Torque during rotation, max.	0.05 Nm @ room temperature
Case material	aluminum alloy
Case surface finish, per MIL-C-5541	chromate conversion coat
Weight, approx.	0.13 kg

General environmental conditions	
Operation	
Ambient temperature range	-40 °C ... +70 °C
Relative humidity, max.	95%
IP protection level	IP60
Storage	
Ambient temperature range	-55 °C ... +70 °C
Relative humidity, max.	95%

DUAL CHANNEL COAX ROTARY JOINT

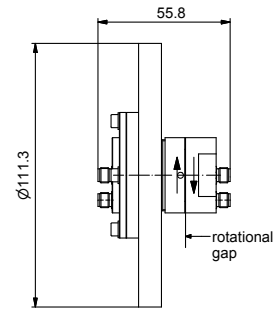
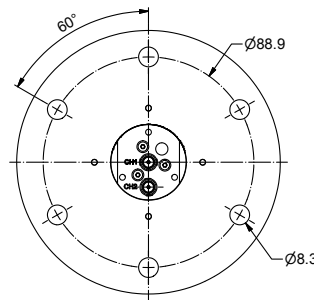
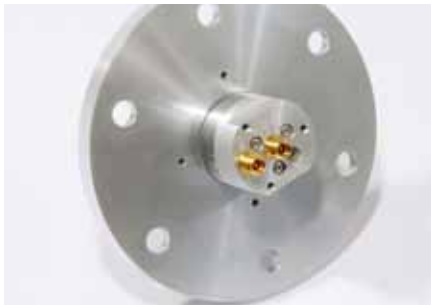

RF channel characteristics	BN 15 31 92	
Channel designation	Channel 1	Channel 2
Interfaces	3.5 mm-f (50 Ω)	3.5 mm-f (50 Ω)
Style	I	I
Frequency range	DC - 18 GHz	DC - 18 GHz
Peak power, max.	1 kW	1 kW
Average power, max.	100 W @ DC - 2 GHz 60 W @ 2 - 4 GHz 35 W @ 4 - 8 GHz 25 W @ 8 - 12 GHz 17 W @ 12 - 18 GHz	10 W
VSWR, max.	1.35 @ DC - 8 GHz 1.50 @ 8 - 18 GHz	2.0 @ DC - 4 GHz 2.5 @ 4 - 8 GHz 3.5 @ 8 - 12 GHz 4.5 @ 12 - 18 GHz
VSWR WOW, max.	0.1	0.1 @ DC - 4 GHz 0.4 @ 4 - 8 GHz 0.8 @ 8 - 12 GHz 2.0 @ 12 - 18 GHz
Insertion loss, max.	0.4 dB @ DC - 8 GHz 1.0 dB @ 8 to 18 GHz	0.5 dB @ DC - 4 GHz 1.0 dB @ 4 - 8 GHz 2.0 dB @ 8 - 12 GHz 3.5 dB @ 12 - 18 GHz
Insertion loss WOW, max.	0.06 dB	0.10 dB @ DC - 4 GHz 0.35 dB @ 4 - 8 GHz 0.70 dB @ 8 - 12 GHz 1.50 dB @ 12 - 18 GHz
Phase WOW, max.	0.5 deg. @ DC - 8 GHz 1.0 deg. @ 8 - 18 GHz	4 deg. @ DC - 8 GHz 10 deg. @ 8 - 12 GHz 25 deg. @ 12 - 18 GHz
Isolation, min.	50 dB	
DC carrying capability, max. (DC applied to one channel only)	0.5 A, 48 VDC @ full RF avg. power 2.0 A, 48 VDC @ RF avg. power 5 W 5.0 A*, 48 VDC @ RF avg. power 5 W	0.5 A, 24 VDC @ full RF avg. power

* Conditions: applied for max. 1 x 10⁶ revolutions

General mechanical data	
Rotating speed, max.	30 rpm
Life, min.	5 x 10 ⁶ revolutions
Starting torque, max.	0.05 Nm @ room temperature
Torque during rotation, max.	0.05 Nm @ room temperature
Case material	aluminum alloy
Case surface finish, per MIL-C-5541	chromate conversion coat
Weight, approx.	0.3 kg

General environmental conditions	
Operation	
Ambient temperature range	-40 °C ... +70 °C
Relative humidity, max.	95%
IP protection level	IP60
Storage	
Ambient temperature range	-55 °C ... +85 °C
Relative humidity, max.	95%

DUAL CHANNEL COAX ROTARY JOINT

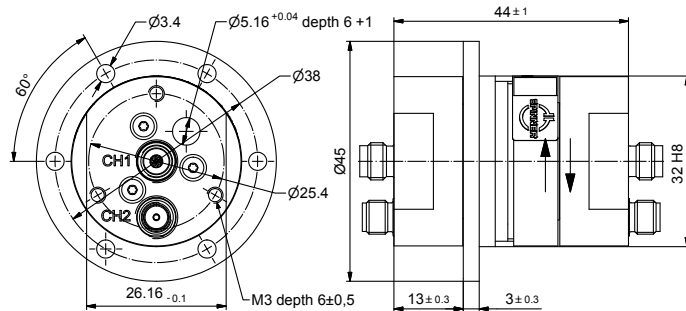

RF channel characteristics	BN 15 31 58	
Channel designation	Channel 1	Channel 2
Interfaces	2.4 mm-f (50 Ω)	SMA-f (50 Ω)
Style	I	I
Frequency range	DC - 50 GHz	DC - 18 GHz
Peak power, max.	1 kW	1 kW
Average power, max.	50 W @ DC to 2 GHz 20 W @ 2 to 4 GHz 5 W @ 4 to 10 GHz 2 W @ 10 to 26.5 GHz 1 W @ 26.5 to 50 GHz	10 W
VSWR, max.	1.3 @ DC to 10 GHz 1.5 @ 10 to 26.5 GHz 1.7 @ 26.5 to 50 GHz	2.0 @ DC - 4 GHz 2.5 @ 4 - 8 GHz 3.5 @ 8 - 12 GHz 4.5 @ 12 - 18 GHz
VSWR WOW, max.	0.1 @ DC to 26.5 GHz 0.3 @ 26.5 to 50 GHz	0.1 @ DC - 4 GHz 0.4 @ 4 - 8 GHz 0.8 @ 8 - 12 GHz 2.0 @ 12 - 18 GHz
Insertion loss, max.	0.4 dB @ DC to 10 GHz 1.0 dB @ 10 to 26.5 GHz 1.5 dB @ 26.5 to 50 GHz	0.5 dB @ DC - 4 GHz 1.0 dB @ 4 - 8 GHz 2.0 dB @ 8 - 12 GHz 3.5 dB @ 12 - 18 GHz
Insertion loss WOW, max.	0.1 dB @ DC to 26.5 GHz 0.2 dB @ 26.5 to 50 GHz	0.10 dB @ DC - 4 GHz 0.35 dB @ 4 - 8 GHz 0.70 dB @ 8 - 12 GHz 1.50 dB @ 12 - 18 GHz
Phase WOW, max.	1 deg. @ DC to 10 GHz 2 deg. @ 10 to 26.5 GHz 3 deg. @ 26.5 to 50 GHz	4 deg. @ DC - 8 GHz 10 deg. @ 8 - 12 GHz 25 deg. @ 12 - 18 GHz
Isolation, min.	50 dB @ DC to 18 GHz	
DC carrying capability, max. (DC applied to one channel only)	not recommended	0.5 A, 24 VDC @ full RF avg. power

General mechanical data	
Rotating speed, max.	30 rpm
Life, min.	5 x 10 ⁶ revolutions
Starting torque, max.	0.05 Nm @ room temperature
Torque during rotation, max.	0.05 Nm @ room temperature
Case material	aluminum alloy
Case surface finish, per MIL-C-5541	chromate conversion coat
Weight, approx.	0.13 kg

General environmental conditions	
Operation	
Ambient temperature range	-40 °C ... +70 °C
Relative humidity, max.	95%
IP protection level	IP60
Storage	
Ambient temperature range	-55 °C ... +70 °C
Relative humidity, max.	95%

DUAL CHANNEL COAX ROTARY JOINT

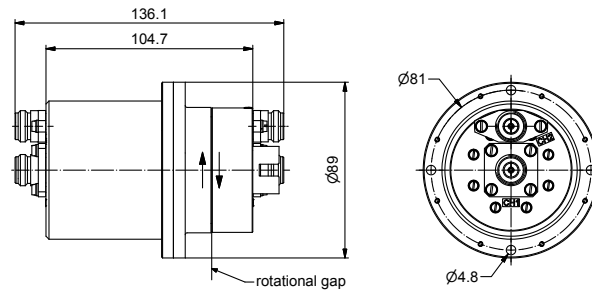

RF channel characteristics	BN 15 31 50	
	Outer Channel 1	Inner Channel 2
Channel designation	Outer Channel 1	Inner Channel 2
Interfaces	N-f (50 Ω)	N-f (50 Ω)
Style	I	I
Frequency range	0.9 - 1.2 GHz	0.9 - 1.2 GHz
Peak power, max.	5 kW *	5 kW *
Average power, max.	250 W	250 W
VSWR, max.	1.2	1.2
VSWR WOW, max.	0.07	0.07
Insertion loss, max.	0.4 dB	0.4 dB
Insertion loss WOW, max.	0.1 dB	0.1 dB
Phase WOW, max.	2 deg.	2 deg.
Isolation, min.	60 dB	

* Conditions: Operating altitude if not pressurized, max. 15000 m; Load VSWR, max. 2

General mechanical data	
Rotating speed, max.	60 rpm
Life, min.	90 x 10 ⁶ revolutions
Starting torque, max.	0.21 Nm @ room temperature
Torque during rotation, max.	0.21 Nm @ room temperature
Case material	copper alloy
Case surface finish	silver plated
Weight, approx.	2.9 kg

General environmental conditions	
Operation	
Ambient temperature range	-40 °C ... +70 °C
Relative humidity, max.	95%
IP protection level	IP50
Storage	
Ambient temperature range	-40 °C ... +70 °C
Relative humidity, max.	95%

DUAL CHANNEL COAX ROTARY JOINT

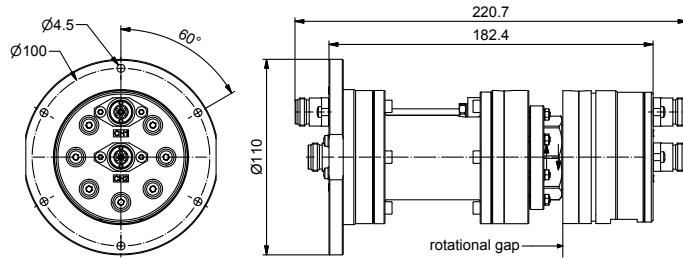

RF channel characteristics	BN 15 31 51	
	Channel 1	Channel 2
Channel designation	Channel 1	Channel 2
Interfaces	N-f (50 Ω)	N-f (50 Ω)
Style	I	I
Frequency range	13.75 - 14.5 GHz	0.1 - 4 GHz
Peak power, max.	200 W *	30 W *
Average power, max.	200 W	30 W @ 0.1 - 2 GHz 20 W @ 2.0 - 4 GHz
VSWR, max.	1.3	1.15 @ 0.1 - 2 GHz 1.25 @ 2.0 - 4 GHz
VSWR WOW, max.	0.10	0.05
Insertion loss, max.	0.7 dB	0.35 dB @ 0.1 - 2 GHz 0.70 dB @ 2.0 - 4 GHz
Isolation, min.	60 dB	

* Conditions: Operating altitude if not pressurized, max. 4000 m; Load VSWR, max. 1.3

General mechanical data	
Absolute operating pressure, min.	0.39 x 10 ⁵ Pa (0.39 bar)
Rotating speed, max.	20 rpm
Life, min.	30 x 10 ⁶ revolutions
Starting torque, max.	5 Nm @ room temperature
Torque during rotation, max.	4 Nm @ room temperature
Case material	aluminium alloy or stainless steel
Case surface finish	chromate conversion coat
Weight, approx.	1.9 kg

General environmental conditions	
Operation	
Ambient temperature range	-40 °C ... +70 °C
Relative humidity, max.	95%
IP protection level	IP53
Storage	
Ambient temperature range	-55 °C ... +85 °C
Relative humidity, max.	95%

DUAL CHANNEL COAX ROTARY JOINT

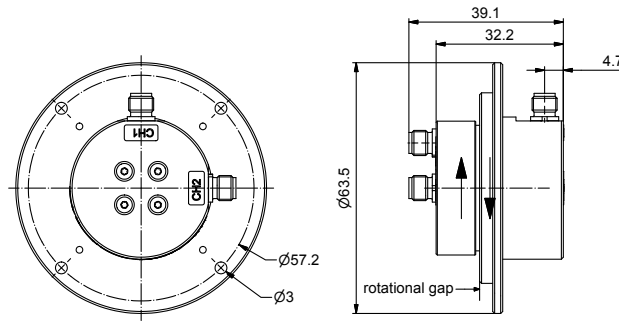

RF channel characteristics	BN 15 31 30	
	Channel 1	Channel 2
Channel designation	Channel 1	Channel 2
Interfaces	2.92 mm-f (50 Ω)	2.92 mm-f (50 Ω)
Style (with corpus interface sidewise)	L	L
Frequency range	19.4 - 21.2 GHz	29.1 - 31 GHz
Peak power, max.	1 kW	1 kW
Average power, max.	1 W	10 W
VSWR, max.	1.5	1.5
VSWR WOW, max.	0.1	0.2 @ 29.1 - 29.5 GHz 0.1 @ 29.5 - 31.0 GHz
Insertion loss, max.	0.8 dB	0.8 dB
Insertion loss WOW, max.	0.1 dB	0.2 @ 29.1 - 29.5 GHz 0.1 @ 29.5 - 31.0 GHz
Isolation, min.	50 dB	

General mechanical data	
Rotating speed, max.	60 rpm
Life, min.	20 x 10 ⁶ revolutions
Starting torque, max.	0.08 Nm @ room temperature
Torque during rotation, max.	0.05 Nm @ room temperature
Case material	aluminium alloy
Case surface finish	chromate conversion coat
Weight, approx.	0.18 kg

General environmental conditions	
Operation	
Ambient temperature range	-55 °C ... +70 °C
Relative humidity, max.	95%
IP protection level	IP41
Storage	
Ambient temperature range	-55 °C ... +85 °C
Relative humidity, max.	95%

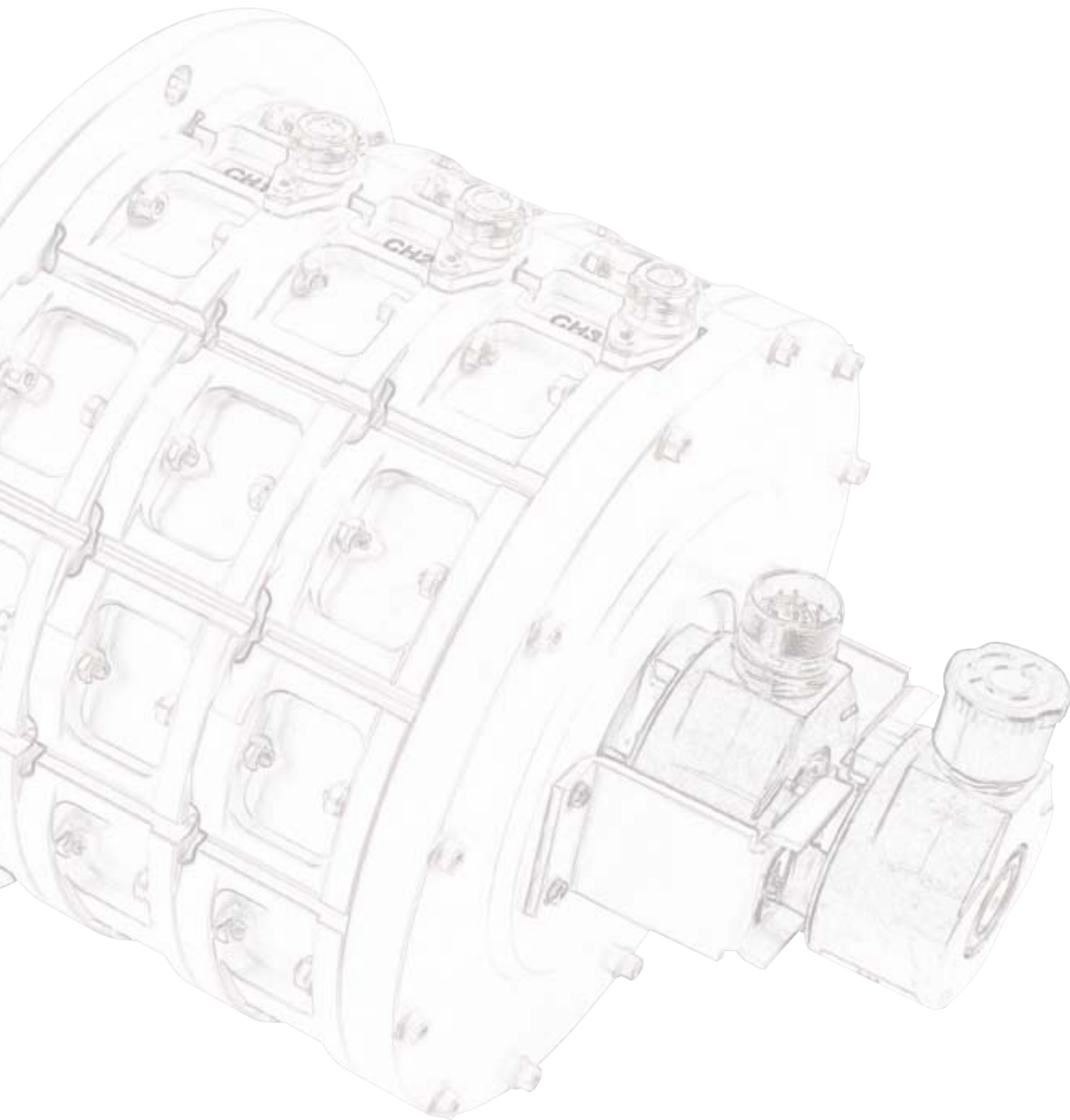

3 CHANNEL ROTARY JOINTS

Part number	Number of channel	Frequency range main channel	Interface	Page
BN 53 23 33	3	0 - 3.0 GHz	SMA-f (50 Ω)	68
BN 53 23 32	3	DC - 3.0 GHz	TNC	69
BN 53 23 49	3	1.0 - 1.1 GHz	N-f (50 Ω)	70
BN 53 25 17	3	1.0 - 1.1 GHz	N-f (50 Ω)	71
BN 53 23 48	3	1.0 - 1.1 GHz	N-f (50 Ω)	72
BN 53 23 52	3	2.7 - 2.9 GHz	N-f (50 Ω)	73



OVERALL SYSTEM | 3 CHANNEL ROTARY JOINT FOR SATCOM

A typical application for the use of such rotary joints is in ground based satellite communication systems. These systems are used to build up a communication link for example in remote areas where no fixed line or WIFI or even mobile communication is available. That happens with the help of a mobile platform that tracks geostationary satellites.

The system itself is installed on a vehicle or trailer and can only be operated when the vehicle or trailer is parked. The azimuth axis of the antenna system allows 360 degrees of rotation due to the use of our rotary joints. The 3 channel rotary joint assembly is used to avoid cable entanglement. Two channels are used as Rx and Tx ports whereas the third channel is kept as spare Rx port. The spare channel is mainly for security reasons to increase the availability of the overall system.



3 CHANNEL COAX ROTARY JOINT

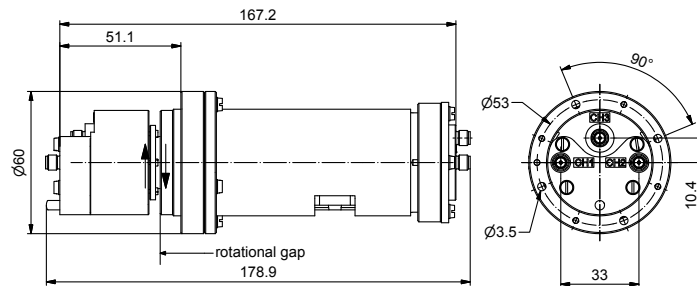

RF channel characteristics	BN 53 23 33		
Channel designation	Channel 1	Channel 2	Channel 3
Interfaces	SMA-f (50 Ω)		
Frequency range	0 - 3.0 GHz		
Peak power, max.	1 kW*		
Average power, max.	50 W @ 1 GHz		
VSWR, max.	1.3	2.0	
VSWR WOW, max.	0.05	0.2	
Insertion loss, max.	0.4 dB	0.7 dB	0.4 dB
Insertion loss WOW, max.	0.1 dB	0.2 dB	
Isolation, min.	60 dB		
Phase WOW, max.	1 deg.	2 deg.	

* Conditions: Operating altitude if not pressurized, max. 3500 m; Load VSWR, max. 2; Pulse width max. 1µs; Pulse repetition rate, max. 3000 Hz

General mechanical data	
Rotating speed, max.	60 rpm
Life, min.	10 x 10 ⁶ revolutions
Starting torque, max.	0.1 Nm @ room temperature
Torque during rotation, max.	0.1 Nm @ room temperature
Case material	aluminium alloy
Case surface finish,	chromate conversion coat
Connector material	copper alloy
Connector surface finish	gold plated
Weight, approx.	0.7 kg

General environmental conditions	
Operation	
Ambient temperature range	-30 °C ... +70 °C
Relative humidity, max.	95%
IP protection level	IP50
Storage	
Ambient temperature range	-40 °C ... +70 °C
Relative humidity, max.	95%

3 CHANNEL COAX ROTARY JOINT

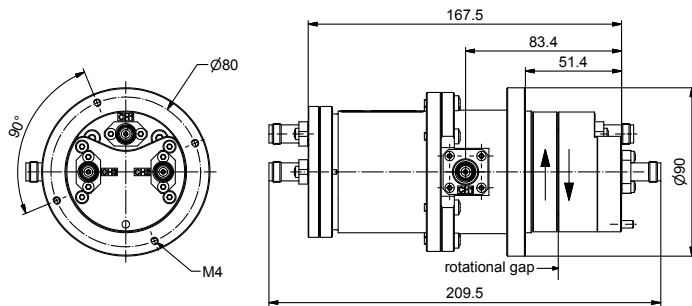

RF channel characteristics	BN 53 23 32		
Channel designation	Channel 1	Channel 2	Channel 3
Interfaces	TNC		
Frequency range	DC - 3.0 GHz		
Peak power, max.	3 kW @ sea level 1.5 KW @ operating altitude: 3000m		
Average power, max.	100 W	30 W	30 W
VSWR, max.	1.3 @ DC to 1 GHz 1.5 @ 1 to 2 GHz 1.7 @ 2 to 3 GHz	1.3 @ DC to 1 GHz 1.5 @ 1 to 2 GHz 1.7 @ 2 to 3 GHz	1.2 @ DC to 1 GHz 1.25 @ 1 to 2 GHz 1.3 @ 2 to 3 GHz
VSWR WOW, max.	0.18	0.18	0.1
Insertion loss, max.	0.75 dB		
Isolation, min.	60 dB		

General mechanical data	
Rotating speed, max.	10 rpm
Life, min.	0.6 x 10 ⁶ revolutions
Starting torque, max.	0.35 Nm @ room temperature
Torque during rotation, max.	0.35 Nm @ room temperature
Case material	aluminium alloy
Case surface finish	chromate conversion coat
Weight, approx.	2 kg

General environmental conditions	
Operation	
Ambient temperature range	-10 °C ... +55 °C
Relative humidity, max.	95%
IP protection level	IP65
Storage	
Ambient temperature range	-20 °C ... +70 °C
Relative humidity, max.	95%

3 CHANNEL COAX ROTARY JOINT

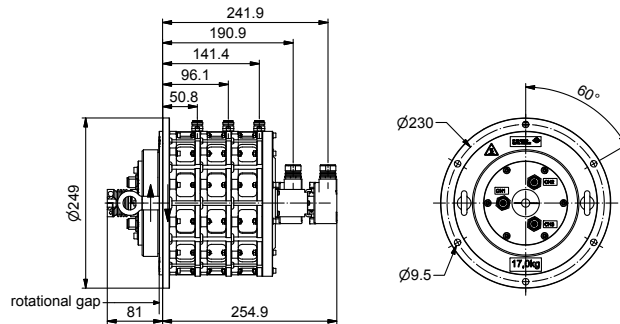

RF channel characteristics		BN 53 23 49		
Channel designation	Channel 1	Channel 2	Channel 3	
Interfaces	N-f (50 Ω)			
Frequency range	1.0 - 1.1 GHz			
Peak power, max.	15 kW			
Average power, max.	200 W			
VSWR, max.	1.25			
VSWR WOW, max.	0.05			
Insertion loss, max.	0.5 dB			
Insertion loss WOW, max.	0.05 dB			
Isolation, min.	60 dB			
Phase WOW, max.	5 deg.			

Encoder Interface characteristics	
Type / manufacturer	2 x DFS60A-TGAA65536 (Fa. SICK-Stegmann AG)

General mechanical data	
Rotating speed, max.	15 rpm
Life, min.	50 x 10 ⁶ revolutions
Starting torque, max.	2 Nm @ room temperature
Torque during rotation, max.	2 Nm @ room temperature
Case material	aluminium alloy
Case surface finish	chromate conversion coat / painted blue (RAL5012)
Weight, approx.	17 kg

General environmental conditions	
Operation	
Ambient temperature range	0 °C ... +70 °C (due to encoder)
Relative humidity, max.	95%
IP protection level	IP40
Storage	
Ambient temperature range	-40 °C ... +70 °C
Relative humidity, max.	95%

3 CHANNEL COAX ROTARY JOINT

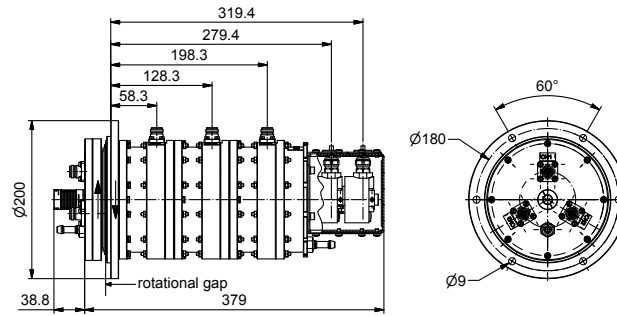

RF channel characteristics	BN 53 25 17		
Channel designation	Channel 1	Channel 2	Channel 3
Interfaces	N-f (50 Ω)		
Frequency range	1.0 - 1.1 GHz		
Peak power, max.	2 kW		
Average power, max.	80 W	10 W	10 W
VSWR, max.	1.25		
VSWR WOW, max.	0.05		
Insertion loss, max.	0.5 dB		
Insertion loss WOW, max.	0.05 dB		
Isolation, min.	60 dB		
Phase WOW, max.	5 deg.		

Encoder Interface characteristics	
Type / manufacturer	2 x DHO5_14//RP29//3600 / BEI-IDEACOD, France

General mechanical data	
Rotating speed, max.	15 rpm
Life, min.	50 x 10 ⁶ revolutions
Starting torque, max.	2 Nm @ room temperature
Torque during rotation, max.	2 Nm @ room temperature
Case material	aluminium alloy
Case surface finish	chromate conversion coat / painted blue (RAL5012)
Weight, approx.	14 kg

General environmental conditions	
Operation	
Ambient temperature range	-40 °C ... +60 °C
Relative humidity, max.	95%
IP protection level	IP40
Storage	
Ambient temperature range	-40 °C ... +60 °C
Relative humidity, max.	95%

3 CHANNEL COAX ROTARY JOINT

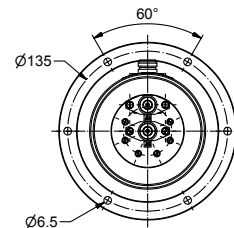
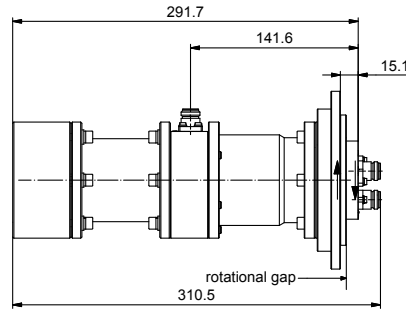

RF channel characteristics	BN 53 23 48		
Channel designation	Channel 1	Channel 2	Channel 3
Interfaces	N-f (50 Ω)		
Frequency range	1.0 - 1.1 GHz		
Peak power, max.	10 kW		
Average power, max.	300 W	50 W	50 W
VSWR, max.	1.2		
VSWR WOW, max.	0.05		
Insertion loss, max.	0.5 dB		
Insertion loss WOW, max.	0.05 dB		
Isolation, min.	50 dB		
Phase WOW, max.	2.5 deg.		

General mechanical data	
Rotating speed, max.	60 rpm
Life, min.	12 x 10 ⁶ revolutions
Starting torque, max.	5 Nm @ room temperature
Torque during rotation, max.	5 Nm @ room temperature
Case material	aluminium alloy
Case surface finish,	aluminium alloy, chromate conversion coat
Weight, approx.	8 kg

General environmental conditions	
Operation	
Ambient temperature range	-40 °C ... +70 °C
Relative humidity, max.	95%
IP protection level	IP50
Storage	
Ambient temperature range	-40 °C ... +70 °C
Relative humidity, max.	95%

3 CHANNEL COAX ROTARY JOINT

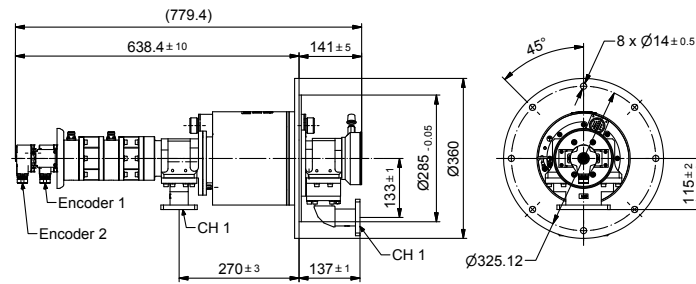
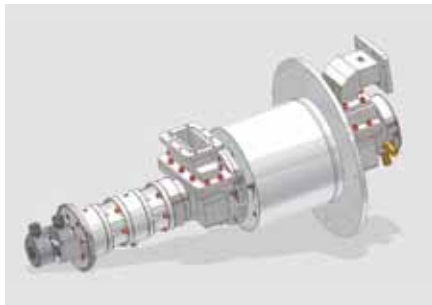

RF channel characteristics	BN 53 23 52		
Channel designation	Channel 1	Channel 2	Channel 3
Interfaces	special flange WR284	N-f (50 Ω)	N-f (50 Ω)
Frequency range	2.7 - 2.9 GHz		
Peak power, max.	35 kW	5 kW	5 kW
Average power, max.	3000 W	75 W	75 W
VSWR, max.	1.2	1.25	1.25
VSWR WOW, max.	0.05	0.05	0.05
Insertion loss, max.	0.15 dB	0.9 dB	1.0 dB
Insertion loss WOW, max.	0.05 dB	0.1 dB	0.1 dB
Phase WOW, max.	2 deg.		
Isolation, min.	60 dB		

* Conditions: Operating altitude if not pressurized, max. 6000 m

Encoder Interface characteristics	
Type / manufacturer	2 x DFS60A-TGAA65536 / Firma SICK
Slip rings characteristics	
Total number of ways	15
General mechanical data	
Differential operating pressure, nom.	0.014 MPa (0.14 bar)
Leakage rate, max.	0.02 MPa (0.2 bar)
Rotating speed, max.	60 rpm
Maintenance cycle, min.	20 x 10 ⁶ revolutions
Starting torque, max.	3 Nm @ room temperature
Torque during rotation, max.	3 Nm @ room temperature
Case material	aluminium alloy
Case surface finish	chromate conversion coat
Weight, approx.	35 kg

General environmental conditions	
Operation	
Ambient temperature range	-20 °C ... +55 °C
Relative humidity, max.	95%
IP protection level	IP53
Altitude, max.	6000 m
Storage	
Ambient temperature range	-40 °C ... +70 °C
Relative humidity, max.	95%

WAVEGUIDE ROTARY JOINTS

Part number	Number of channel	Frequency range main channel	Interface	Page
BN 63 48 08	1	2.025 - 2.125 GHz	CPR 430/G	76
BN 63 53 23	1	2.70 - 2.90 GHz	CPR 284/G	77
BN 63 47 39	1	5.4 - 5.9 GHz	CPR 187/G	78
BN 63 47 36	1	5.82 - 7.00 GHz	CPR 159/F	79
BN 63 47 37	1	5.82 - 7.00 GHz	CPR 159/F	80
BN 63 49 12	1	5.85 - 7.00 GHz	CPR 137/G with thread M4	81
BN 63 49 13	1	5.850 - 6.725 GHz	CPR 137/G with thread M4	82
BN 63 49 14	1	6.5 - 7.5 GHz	CPR 137/G with thread M4	83
BN 63 49 11	1	5.6 - 7.25 GHz	CPR 137/G with thread M4	84
BN 63 57 21	1	7.0 - 8.6 GHz	154 IEC UBR84	85
BN 63 57 22	1	7.0 - 8.6 GHz	154 IEC UBR84 with thread M4	86
BN 63 57 20	1	7.0 - 8.6 GHz	154 IEC UBR84 with thread M4	87
BN 63 50 05	1	8.5 - 10.0 GHz	UBR100	88
BN 63 50 14	1	8.5 - 10.0 GHz	154 IEC UBR100 with thread M4	89
BN 63 50 15	1	8.5 - 10.0 GHz	154 IEC UBR100 with thread M4	90
BN 63 50 16	1	8.5 - 10.0 GHz	UBR84	91
BN 63 57 09	1	10.70 - 14.50 GHz	PBR120 / UBR120 with thread M4	92
BN 63 57 10	1	10.70 - 14.50 GHz	PBR120	93
BN 63 57 18	1	10.70 - 14.50 GHz	PBR120	94
BN 63 57 07	1	10.70 - 14.50 GHz	UBR120 with thread M4	95
BN 63 57 25	1	13.75 - 14.50 GHz	UBR120	96
BN 63 57 26	1	13.75 - 14.50 GHz	UBR120	97
BN 63 57 17	1	14.00 - 14.50 GHz	154 IEC UBR120	98
BN 83 50 92	1	30.0 - 31.0 GHz	154 IEC PBR320 with thread M2.5	99
BN 63 62 94	1	93.0 - 95.0 GHz	UG-387 / U-mod	100
BN 63 62 95	1	93.0 - 95.0 GHz	UG-387 / U-mod	100
BN 63 62 96	1	93.0 - 95.0 GHz	UG-387 / U-mod	100
BN 63 62 97	1	93.0 - 95.0 GHz	UG-387 / U-mod	100



WAVEGUIDE ROTARY JOINTS

Military and civil solutions for radar, satellite communication and space applications require waveguide rotary joints. SPINNER offers the complete range up to 94 GHz to help its customers with outstanding solutions.

The product line follows a common design philosophy that is characterized by excellent electrical and mechanical performance, allied to a highly reliable design. Although realised in a non-contacting design which guarantees a long lifetime of a minimum of 20 million revolutions, SPINNER's waveguide rotary joints are characterised by large frequency bandwidth and high power capability.

Advanced electromagnetic designs employing milled impedance transformers result in superior return loss and insertions loss figures.

Excellent electrical and mechanical performance and longest lifetime define these solutions as a reference standard.

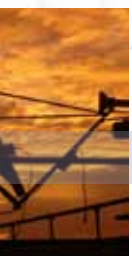
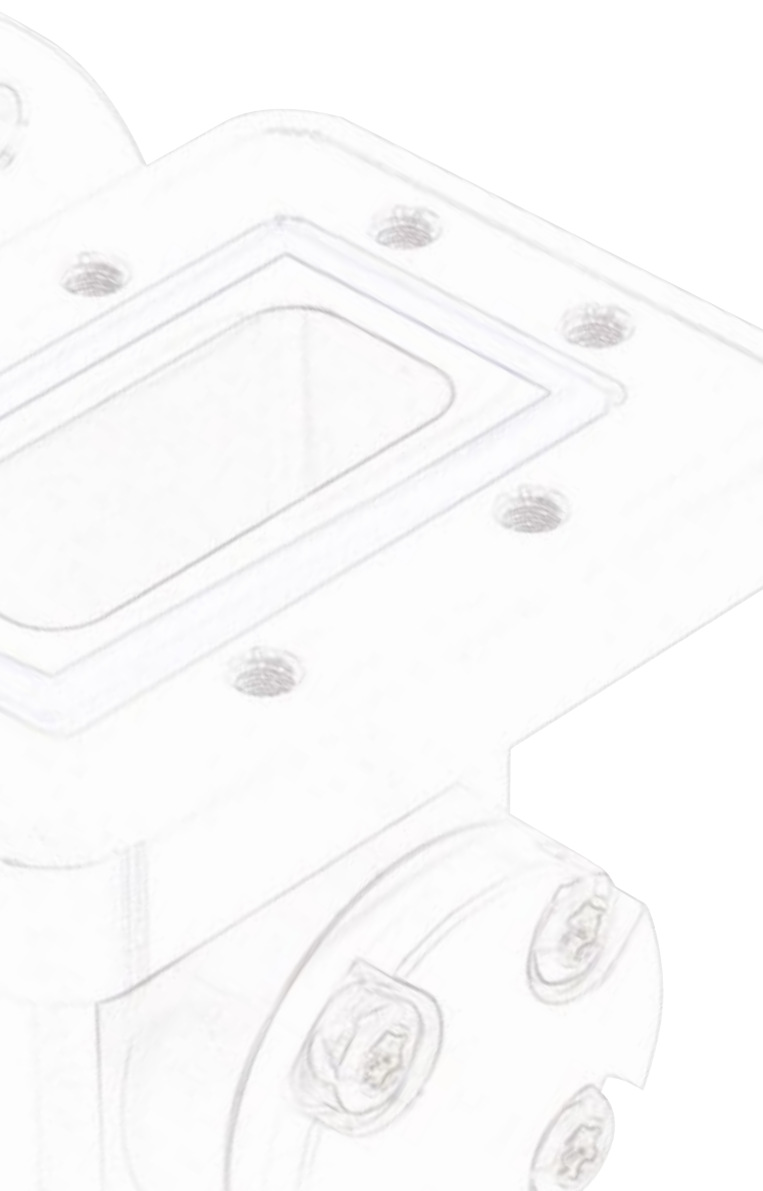

SINGLE CHANNEL WAVEGUIDE ROTARY JOINT

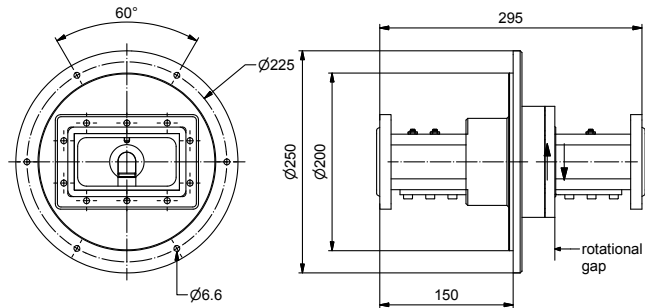

RF channel characteristics	BN 63 48 08
Interfaces	CPR 430/G
Style	I
Frequency range	2.025 - 2.125 GHz
Peak power, max.	100 kW
Average power, max.	5 kW
VSWR, max.	1.1
VSWR WOW, max.	0.04
Insertion loss, max.	0.15 dB
Insertion loss WOW, max.	0.02 dB
Phase WOW, max.	2 deg.

General mechanical data	
Differential operating pressure, nom.	0.5 x 10 ⁵ Pa (0.5 bar)
Leakage rate, max.	3 cm ³ /minute
Rotating speed, max.	60 rpm
Life, min.	10 x 10 ⁶ revolutions
Starting torque, max.	2 Nm @ room temperature
Torque during rotation, max.	2 Nm @ room temperature
Case material	copper alloy
Case surface finish	painting dark grey (RAL 7021)
Weight, approx.	14.7 kg

General environmental conditions	
Operation	
Ambient temperature range	-40 °C ... +55 °C
Relative humidity, max.	95%
IP protection level	IP65
Storage	
Ambient temperature range	-50 °C ... +70 °C
Relative humidity, max.	95%

SINGLE CHANNEL WAVEGUIDE ROTARY JOINT

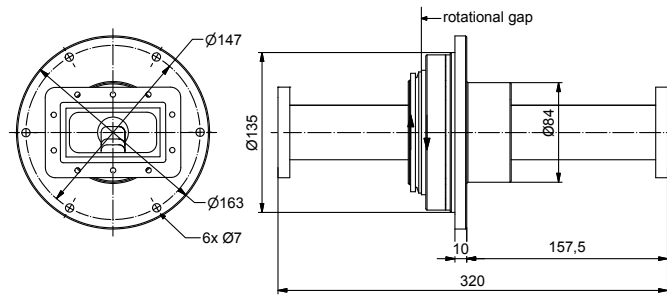
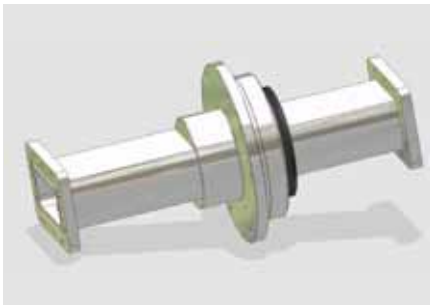

RF channel characteristics	BN 63 53 23
Interfaces	CPR 284/G
Style	I
Frequency range	2.70 - 2.90 GHz
Peak power, max.	1 MW *
Average power, max.	1 kW
VSWR, max.	1.2
VSWR WOW, max.	0.05
Insertion loss, max.	0.2 dB
Insertion loss WOW, max.	0.05 dB
Phase WOW, max.	3 deg.

* Conditions: Operating altitude if not pressurized, max. 2000 m

General mechanical data	
Differential operating pressure, nom.	2 x 10 ⁵ Pa (2.1 bar)
Leakage rate, max.	20 cm ³ /minute
Rotating speed, max.	10 rpm
Life, min.	6 x 10 ⁶ revolutions
Starting torque, max.	5 Nm @ room temperature
Torque during rotation, max.	5 Nm @ room temperature
Case material	aluminum alloy
Case surface finish	painted dark grey (RAL 7021)
Weight, approx.	2.4 kg

General environmental conditions	
Operation	
Ambient temperature range	0 °C ... +55 °C
Relative humidity, max.	95%
IP protection level	IP65
Storage	
Ambient temperature range	-20 °C ... +60 °C
Relative humidity, max.	95%

SINGLE CHANNEL WAVEGUIDE ROTARY JOINT

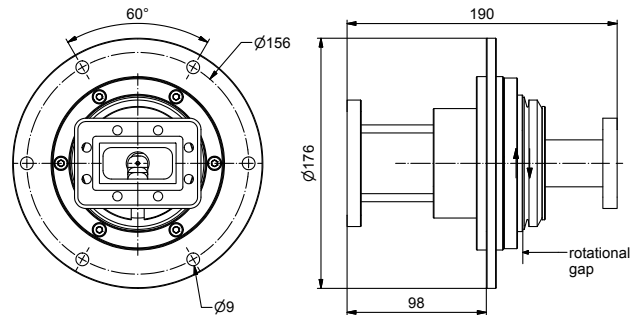
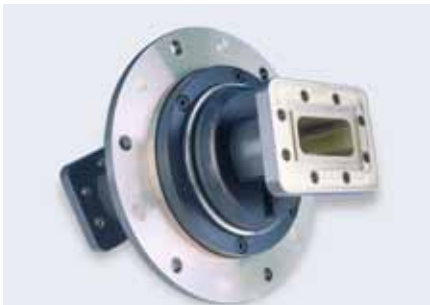

RF channel characteristics	BN 63 47 39
Interfaces	CPR 187/G
Style	I
Frequency range	5.4 - 5.9 GHz
Peak power, max.	1.1 MW*
Average power, max.	4 kW
VSWR, max.	1.2
VSWR WOW, max.	1.05
Insertion loss, max.	0.2 dB
Insertion loss WOW, max.	0.05 dB
Phase WOW, max.	3 deg.

* Conditions: Pressurization with dry air at the abs. pressure, min. 2.0×10^5 Pa (2.0 bar)

General mechanical data	
Differential operating pressure, nom.	2.1×10^5 Pa (2.1 bar)
Leakage rate, max.	20 cm ³ /minute
Rotating speed, max.	10 rpm
Life, min.	6×10^6 revolutions
Starting torque, max.	5 Nm @ room temperature
Torque during rotation, max.	5 Nm @ room temperature
Case material	aluminum alloy
Case surface finish	painted dark grey (RAL 7021)
Weight, approx.	2.4 kg

General environmental conditions	
Operation	
Ambient temperature range	0 °C ... +55 °C
Relative humidity, max.	95%
IP protection level	IP65
Storage	
Ambient temperature range	-20 °C ... +60 °C
Relative humidity, max.	95%

SINGLE CHANNEL WAVEGUIDE ROTARY JOINT

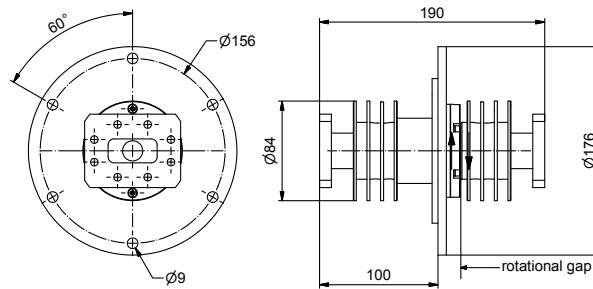

RF channel characteristics	BN 63 47 36
Interfaces	CPR 159/F
Style	I
Frequency range	5.82 - 7.00 GHz
Peak power, max.	70 kW
Average power, max.	10 kW
VSWR, max.	1.15
VSWR WOW, max.	0.04
Insertion loss, max.	0.15 dB
Insertion loss WOW, max.	0.04 dB
Phase WOW, max.	2 deg.

General mechanical data	
Differential operating pressure, nom.	0.5 x 10 ⁵ Pa (0.5 bar)
Leakage rate, max.	3 cm ³ /minute
Rotating speed, max.	60 rpm
Life, min.	10 x 10 ⁶ revolutions
Starting torque, max.	2 Nm @ room temperature
Torque during rotation, max.	2 Nm @ room temperature
Case material	aluminum alloy
Case surface finish	painted black (RAL 9005)
Weight, approx.	3 kg

General environmental conditions	
Operation	
Ambient temperature range	-40 °C ... +70 °C
Relative humidity, max.	95%
IP protection level	IP64
Storage	
Ambient temperature range	-50 °C ... +85 °C
Relative humidity, max.	95%

SINGLE CHANNEL WAVEGUIDE ROTARY JOINT

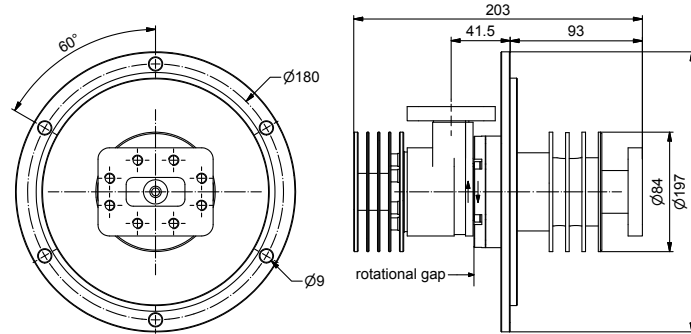
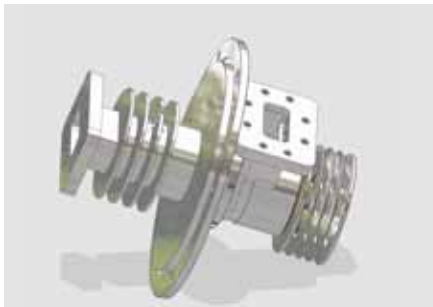

RF channel characteristics	BN 63 47 37
Interfaces	CPR 159/F
Style	L
Frequency range	5.82 -7.0 GHz
Peak power, max.	70 kW
Average power, max.	10 kW
VSWR, max.	1.15
VSWR WOW, max.	0.04
Insertion loss, max.	0.15 dB
Insertion loss WOW, max.	0.04 dB
Phase WOW, max.	2 deg.

General mechanical data	
Differential operating pressure, nom.	0.5 x 10 ⁵ Pa (0.5 bar)
Leakage rate, max.	3 cm ³ /minute
Rotating speed, max.	60 rpm
Life, min.	10 x 10 ⁶ revolutions
Starting torque, max.	2 Nm @ room temperature
Torque during rotation, max.	2 Nm @ room temperature
Case material	aluminum alloy
Case surface finish	painted black (RAL 9005)
Weight, approx.	3 kg

General environmental conditions	
Operation	
Ambient temperature range	-40 °C ... +70 °C
Relative humidity, max.	95%
IP protection level	IP64
Storage	
Ambient temperature range	-50 °C ... +85 °C
Relative humidity, max.	95%

SINGLE CHANNEL WAVEGUIDE ROTARY JOINT

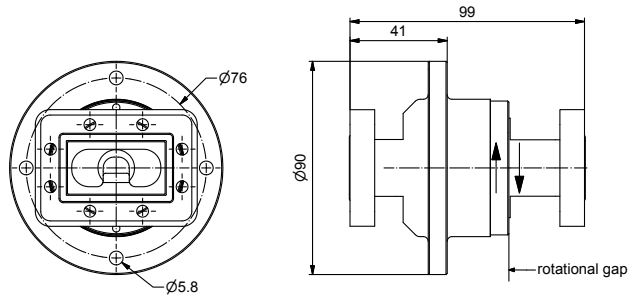

RF channel characteristics	BN 63 49 12
Interfaces	CPR 137/G with thread M4
Style	I
Frequency range	5.85 - 7.00 GHz
Peak power, max.	10 kW *
Average power, max.	3.5 kW
VSWR, max.	1.15
VSWR WOW, max.	0.05
Insertion loss, max.	0.1 dB
Insertion loss WOW, max.	0.05 dB
Phase WOW, max.	2 deg.

* Conditions: Operating altitude if not pressurized, max. 3000 m; Load VSWR, max. 2.0

General mechanical data	
Differential operating pressure, nom.	2 x 10 ⁵ Pa (2.0 bar)
Leakage rate, max.	10 cm ³ /minute
Rotating speed, max.	120 rpm
Life, min.	10 x 10 ⁶ revolutions
Starting torque, max.	0.7 Nm @ room temperature
Torque during rotation, max.	0.8 Nm @ room temperature
Case material	aluminum alloy
Case surface finish	chromate conversion coat
Weight, approx.	0.7 kg

General environmental conditions	
Operation	
Ambient temperature range	-40 °C ... +70 °C
Relative humidity, max.	95%
IP protection level	IP64
Storage	
Ambient temperature range	-55 °C ... +70 °C
Relative humidity, max.	95%

SINGLE CHANNEL WAVEGUIDE ROTARY JOINT

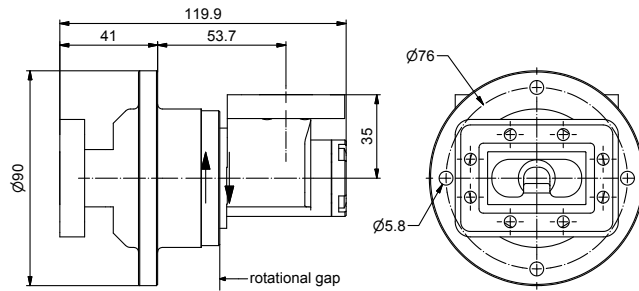

RF channel characteristics	BN 63 49 13
Interfaces	CPR 137/G with thread M4
Style	L with corpus interface in-line
Frequency range	5.850 - 6.725 GHz
Peak power, max.	10 kW *
Average power, max.	3.5 kW
VSWR, max.	1.15
VSWR WOW, max.	0.05
Insertion loss, max.	0.1 dB
Insertion loss WOW, max.	0.05 dB
Phase WOW, max.	2 deg.

* Conditions: Operating altitude if not pressurized, max. 3000 m; Load VSWR, max. 2.0

General mechanical data	
Differential operating pressure, nom.	2 x 10 ⁵ Pa (2.0 bar)
Leakage rate, max.	10 cm ³ /minute
Rotating speed, max.	120 rpm
Life, min.	10 x 10 ⁶ revolutions
Starting torque, max.	0.7 Nm @ room temperature
Torque during rotation, max.	0.8 Nm @ room temperature
Case material	aluminum alloy
Case surface finish	chromate conversion coat
Weight, approx.	0.8 kg

General environmental conditions	
Operation	
Ambient temperature range	-40 °C ... +70 °C
Relative humidity, max.	95%
IP protection level	IP64
Storage	
Ambient temperature range	-55 °C ... +70 °C
Relative humidity, max.	95%

SINGLE CHANNEL WAVEGUIDE ROTARY JOINT

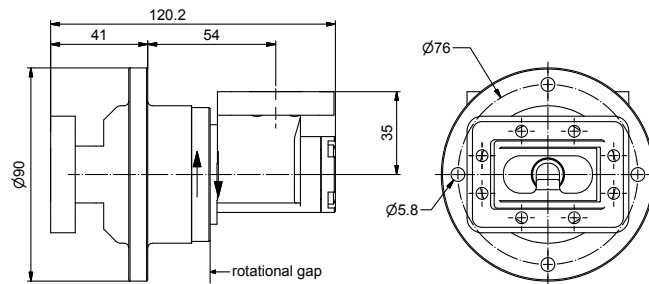

RF channel characteristics	BN 63 49 14
Interfaces	CPR 137/G with thread M4
Style	L
Frequency range	6.5 - 7.5 GHz
Peak power, max.	10 kW *
Average power, max.	3.5 kW
VSWR, max.	1.15
VSWR WOW, max.	0.05
Insertion loss, max.	0.1 dB
Insertion loss WOW, max.	0.05 dB
Phase WOW, max.	2 deg.

* Conditions: Operating altitude if not pressurized, max. 3000 m; Load VSWR, max. 2.0

General mechanical data	
Differential operating pressure, nom.	2 x 10 ⁵ Pa (2.0 bar)
Leakage rate, max.	10 cm ³ /minute
Rotating speed, max.	120 rpm
Life, min.	10 x 10 ⁶ revolutions
Starting torque, max.	0.7 Nm @ room temperature
Torque during rotation, max.	0.8 Nm @ room temperature
Case material	aluminum alloy
Case surface finish	chromate conversion coat
Weight, approx.	0.8 kg

General environmental conditions	
Operation	
Ambient temperature range	-40 °C ... +70 °C
Relative humidity, max.	95%
IP protection level	IP64
Storage	
Ambient temperature range	-55 °C ... +70 °C
Relative humidity, max.	95%

SINGLE CHANNEL WAVEGUIDE ROTARY JOINT

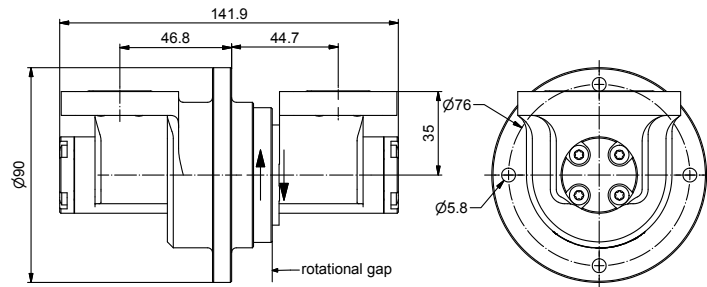

RF channel characteristics	BN 63 49 11
Interfaces	CPR 137/G with thread M4
Style	U
Frequency range	5.6 - 7.25 GHz
Peak power, max.	10 kW *
Average power, max.	3.5 kW
VSWR, max.	1.15
VSWR WOW, max.	0.05
Insertion loss, max.	0.1 dB
Insertion loss WOW, max.	0.05 dB
Phase WOW, max.	2 deg.

* Conditions: Operating altitude if not pressurized, max. 3000 m; Load VSWR, max. 2.0

General mechanical data	
Differential operating pressure, nom.	2 x 10 ⁵ Pa (2.0 bar)
Leakage rate, max.	10 cm ³ /minute
Rotating speed, max.	120 rpm
Life, min.	10 x 10 ⁶ revolutions
Starting torque, max.	0.7 Nm @ room temperature
Torque during rotation, max.	0.8 Nm @ room temperature
Case material	aluminum alloy
Case surface finish	chromate conversion coat
Weight, approx.	0.92 kg

General environmental conditions	
Operation	
Ambient temperature range	-40 °C ... +70 °C
Relative humidity, max.	95%
IP protection level	IP64
Storage	
Ambient temperature range	-55 °C ... +70 °C
Relative humidity, max.	95%

SINGLE CHANNEL WAVEGUIDE ROTARY JOINT

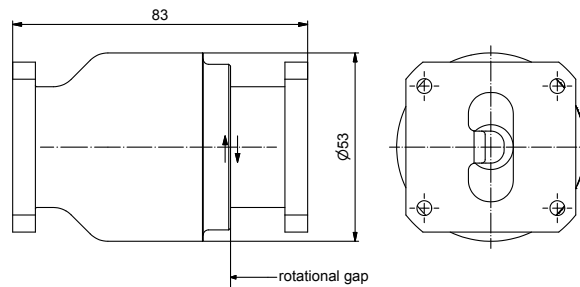

RF channel characteristics	BN 63 57 21
Interfaces	154 IEC UBR84
Style	I
Frequency range	7 - 8.6 GHz
Peak power, max.	10 kW*
Average power, max.	1 kW
VSWR, max.	1.15
VSWR WOW, max.	0.05
Insertion loss, max.	0.15 dB
Insertion loss WOW, max.	0.05 dB
Phase WOW, max.	2 deg.

* Conditions: Operating altitude if not pressurized, max. 3000 m; Load VSWR, max. 2.0

General mechanical data	
Differential operating pressure, nom.	2×10^5 Pa (2.0 bar)
Leakage rate, max.	10 cm ³ /minute
Rotating speed, max.	120 rpm
Life, min.	20×10^6 revolutions
Starting torque, max.	0.6 Nm @ room temperature
Torque during rotation, max.	0.7 Nm @ room temperature
Case material	aluminum alloy
Case surface finish	chromate conversion coat
Weight, approx.	0.45 kg

General environmental conditions	
Operation	
Ambient temperature range	-40 °C ... +70 °C
Relative humidity, max.	95%
IP protection level	IP64
Storage	
Ambient temperature range	-55 °C ... +70 °C
Relative humidity, max.	95%

SINGLE CHANNEL WAVEGUIDE ROTARY JOINT

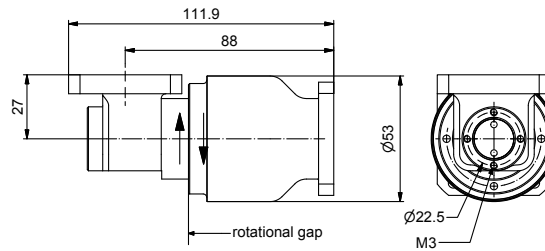

RF channel characteristics	BN 63 57 22
Interfaces	154 IEC UBR84 with thread M4
Style	L
Frequency range	7.0 - 8.6 GHz
Peak power, max.	10 kW*
Average power, max.	1 kW
VSWR, max.	1.15
VSWR WOW, max.	0.05
Insertion loss, max.	0.15 dB
Insertion loss WOW, max.	0.05 dB
Phase WOW, max.	2 deg.

* Conditions: Operating altitude if not pressurized, max. 3000 m; Load VSWR, max. 2.0

General mechanical data	
Differential operating pressure, nom.	2×10^5 Pa (2 bar)
Leakage rate, max.	10 cm ³ /minute
Rotating speed, max.	120 rpm
Life, min.	20×10^6 revolutions
Starting torque, max.	0.6 Nm @ room temperature
Torque during rotation, max.	0.7 Nm @ room temperature
Case material	aluminum alloy
Case surface finish	chromate conversion coat
Weight, approx.	0.50 kg

General environmental conditions	
Operation	
Ambient temperature range	-40 °C ... +70 °C
Relative humidity, max.	95%
IP protection level	IP65
Storage	
Ambient temperature range	-55 °C ... +70 °C
Relative humidity, max.	95%

SINGLE CHANNEL WAVEGUIDE ROTARY JOINT

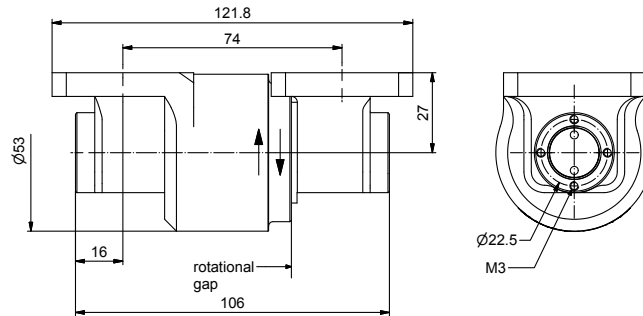

RF channel characteristics	BN 63 57 20
Interfaces	154 IEC UBR84 with thread M4
Style	U
Frequency range	7.0 - 8.6 GHz
Peak power, max.	10 kW*
Average power, max.	1 kW
VSWR, max.	1.15
VSWR WOW, max.	0.05
Insertion loss, max.	0.15 dB
Insertion loss WOW, max.	0.05 dB
Phase WOW, max.	2 deg.

* Conditions: Operating altitude if not pressurized, max. 3000 m; Load VSWR, max. 2.0

General mechanical data	
Differential operating pressure, nom.	2 x 10 ⁵ Pa (2 bar)
Leakage rate, max.	10 cm ³ /minute
Rotating speed, max.	120 rpm
Life, min.	20 x 10 ⁶ revolutions
Starting torque, max.	0.6 Nm @ room temperature
Torque during rotation, max.	0.7 Nm @ room temperature
Case material	aluminum alloy
Case surface finish	chromate conversion coat
Weight, approx.	0.55 kg

General environmental conditions	
Operation	
Ambient temperature range	-40 °C ... +70 °C
Relative humidity, max.	95%
IP protection level	IP65
Storage	
Ambient temperature range	-55 °C ... +70 °C
Relative humidity, max.	95%

SINGLE CHANNEL WAVEGUIDE ROTARY JOINT

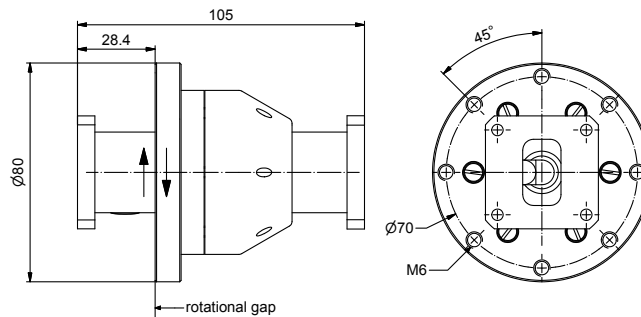
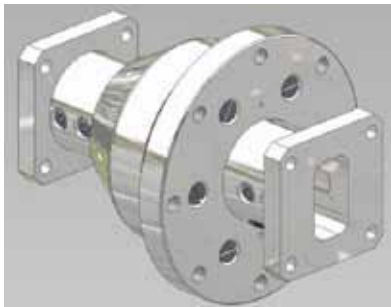

RF channel characteristics	BN 63 50 05
Interfaces	UBR100
Style	I
Frequency range	8.5 - 10 GHz
Peak power, max.	220 kW* 100 kW** 50 kW*** 2 kW****
Average power, max.	300 W
VSWR, max.	1.20 @ 8.5 to 9 GHz 1.15 @ 9 to 9.6 GHz 1.20 @ 9.6 to 10 GHz
VSWR WOW, max.	0.03
Insertion loss, max.	0.15 dB
Insertion loss WOW, max.	0.05 dB

Conditions: * Waveguide pressurized with dry air at absolute pressure, min: 2.0×10^5 Pa (2 bar)
 ** Operating altitude if not pressurized at sea level; *** Operating altitude if not pressurized at 3500 m;
 **** Operating altitude if not pressurized, max. 10000 m

General mechanical data	
Differential operating pressure, nom.	2×10^5 Pa (2.0 bar)
Leakage rate, max.	20 cm ³ /minute
Rotating speed, max.	60 rpm
Life, min.	10×10^6 revolutions
Starting torque, max.	0.8 Nm @ room temperature
Torque during rotation, max.	0.7 Nm @ room temperature
Case material	aluminum alloy
Case surface finish	painted black (RAL 9005)
Weight, approx.	0.5 kg

General environmental conditions	
Operation	
Ambient temperature range	-40 °C ... +71 °C
Relative humidity, max.	95%
IP protection level	IP65
Storage	
Ambient temperature range	-50 °C ... +85 °C
Relative humidity, max.	95%

SINGLE CHANNEL WAVEGUIDE ROTARY JOINT

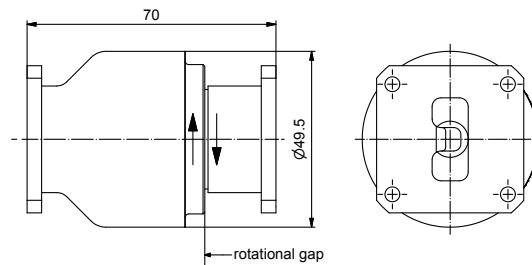

RF channel characteristics	BN 63 50 14
Interfaces	154 IEC UBR100 with thread M4
Style	I
Frequency range	8.5 - 10 GHz
Peak power, max.	7.5 kW*
Average power, max.	500 W
VSWR, max.	1.15
VSWR WOW, max.	0.05
Insertion loss, max.	0.15 dB
Insertion loss WOW, max.	0.05 dB
Phase WOW, max.	2 deg.

* Conditions: Operating altitude if not pressurized, max. 3000 m; Load VSWR, max. 2.0

General mechanical data	
Differential operating pressure, nom.	0.2 MPa (2 bar)
Leakage rate, max.	20 cm ³ /minute
Rotating speed, max.	120 rpm
Life, min.	20 x 10 ⁶ revolutions
Starting torque, max.	0.7 Nm @ room temperature
Torque during rotation, max.	0.8 Nm @ room temperature
Case material	aluminum alloy
Case surface finish	chromate conversion coat
Weight, approx.	0.35 kg

General environmental conditions	
Operation	
Ambient temperature range	-40 °C ... +70 °C
Relative humidity, max.	95%
IP protection level	IP65
Storage	
Ambient temperature range	-55 °C ... +70 °C
Relative humidity, max.	95%

SINGLE CHANNEL WAVEGUIDE ROTARY JOINT

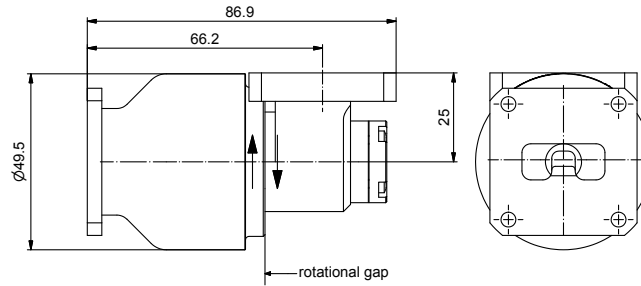

RF channel characteristics	BN 63 50 15
Interfaces	154 IEC UBR100 with thread M4
Style	L
Frequency range	8.5 - 10 GHz
Peak power, max.	7.5 kW*
Average power, max.	500 W
VSWR, max.	1.15
VSWR WOW, max.	0.05
Insertion loss, max.	0.15 dB
Insertion loss WOW, max.	0.05 dB
Phase WOW, max.	2 deg.

* Conditions: Operating altitude if not pressurized, max. 3000 m; Load VSWR, max. 2.0

General mechanical data	
Differential operating pressure, nom.	0.2 MPa (2 bar)
Leakage rate, max.	20 cm ³ /minute
Rotating speed, max.	120 rpm
Life, min.	20 x 10 ⁶ revolutions
Starting torque, max.	0.7 Nm @ room temperature
Torque during rotation, max.	0.8 Nm @ room temperature
Case material	aluminum alloy
Case surface finish	chromate conversion coat
Weight, approx.	0.35 kg

General environmental conditions	
Operation	
Ambient temperature range	-40 °C ... +70 °C
Relative humidity, max.	95%
IP protection level	IP65
Storage	
Ambient temperature range	-55 °C ... +70 °C
Relative humidity, max.	95%

SINGLE CHANNEL WAVEGUIDE ROTARY JOINT

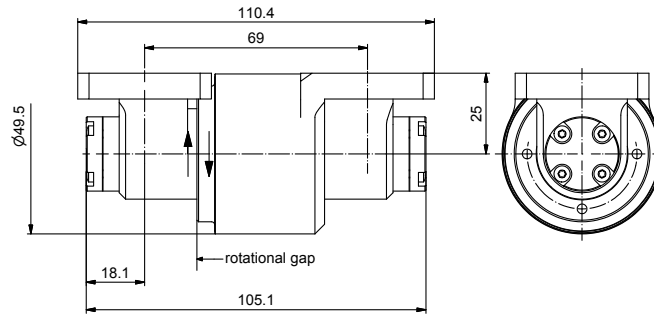

RF channel characteristics	BN 63 50 16
Interfaces	UBR84
Style	U
Frequency range	8.5 - 10.0 GHz
Peak power, max.	7.5 kW*
Average power, max.	500 W
VSWR, max.	1.15
VSWR WOW, max.	0.05
Insertion loss, max.	0.15 dB
Insertion loss WOW, max.	0.05 dB
Phase WOW, max.	2 deg.

* Conditions: Operating altitude if not pressurized, max. 3000 m; Load VSWR, max. 2.0

General mechanical data	
Differential operating pressure, nom.	0.2 MPa (2 bar)
Leakage rate, max.	20 cm ³ /minute
Rotating speed, max.	120 rpm
Life, min.	20 x 10 ⁶ revolutions
Starting torque, max.	0.7 Nm @ room temperature
Torque during rotation, max.	0.8 Nm @ room temperature
Case material	aluminum alloy
Case surface finish	chromate conversion coat
Weight, approx.	0.45 kg

General environmental conditions	
Operation	
Ambient temperature range	-40 °C ... +70 °C
Relative humidity, max.	95%
IP protection level	IP65
Storage	
Ambient temperature range	-55 °C ... +70 °C
Relative humidity, max.	95%

SINGLE CHANNEL WAVEGUIDE ROTARY JOINT

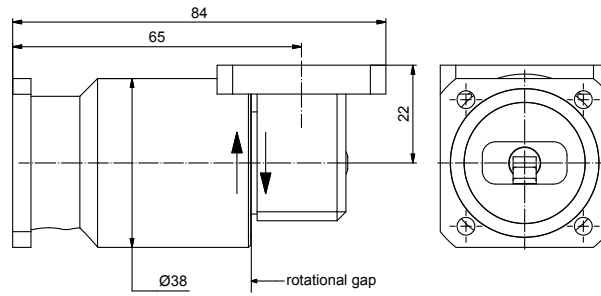

RF channel characteristics	BN 63 57 09
Interfaces	axial port: PBR120 radial port: UBR120 with thread M4
Style	L
Frequency range	10.70 - 14.50 GHz
Peak power, max.	5 kW*
Average power, max.	750 W
VSWR, max.	1.2
VSWR WOW, max.	0.05
Insertion loss, max.	0.2 dB
Insertion loss WOW, max.	0.1 dB
Phase WOW, max.	2 deg.

* Conditions: Operating altitude if not pressurized, max. 2000 m

General mechanical data	
Differential operating pressure, nom.	2 x 10 ⁵ Pa (2.0 bar)
Leakage rate, max.	10 cm ³ /minute
Rotating speed, max.	120 rpm
Life, min.	20 x 10 ⁶ revolutions
Starting torque, max.	0.25 Nm @ room temperature
Torque during rotation, max.	0.20 Nm @ room temperature
Case material	aluminum alloy
Case surface finish	chromate conversion coat
Weight, approx.	0.23 kg

General environmental conditions	
Operation	
Ambient temperature range	-40 °C ... +70 °C
Relative humidity, max.	95%
IP protection level	IP65
Storage	
Ambient temperature range	-55 °C ... +70 °C
Relative humidity, max.	95%

SINGLE CHANNEL WAVEGUIDE ROTARY JOINT

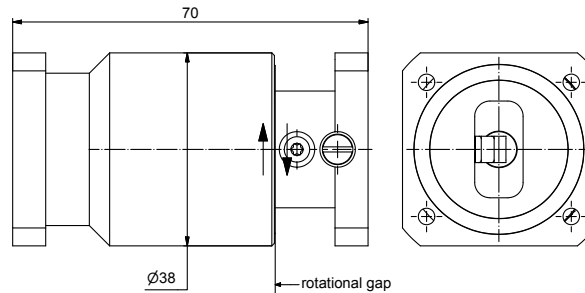

RF channel characteristics	BN 63 57 10
Interfaces	PBR120
Style	I
Frequency range	10.70 - 14.50 GHz
Peak power, max.	5 kW*
Average power, max.	750 W
VSWR, max.	1.2
VSWR WOW, max.	0.05
Insertion loss, max.	0.2 dB
Insertion loss WOW, max.	0.1 dB
Phase WOW, max.	2 deg.

* Conditions: Operating altitude, max. 2000 m

General mechanical data	
Differential operating pressure, nom.	2 x 10 ⁵ Pa (2 bar)
Leakage rate, max.	10 cm ³ /minute
Rotating speed, max.	120 rpm
Life, min.	20 x 10 ⁶ revolutions
Starting torque, max.	0.25 Nm @ room temperature
Torque during rotation, max.	0.20 Nm @ room temperature
Case material	aluminum alloy
Case surface finish	chromate conversion coat per MIL-C-5541
Weight, approx.	0.25 kg

General environmental conditions	
Operation	
Ambient temperature range	-40 °C ... +70 °C
Relative humidity, max.	95%
IP protection level	IP65
Storage	
Ambient temperature range	-55 °C ... +70 °C
Relative humidity, max.	95%

SINGLE CHANNEL WAVEGUIDE ROTARY JOINT

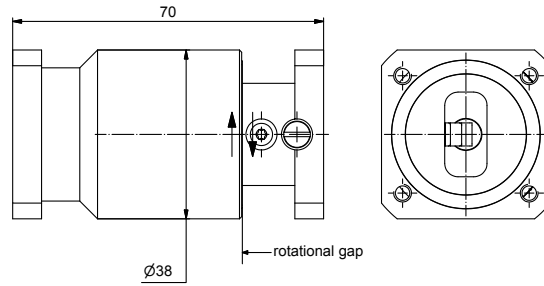

RF channel characteristics	BN 63 57 18
Interfaces	PBR120
Style	I
Frequency range	10.70 - 14.50 GHz
Peak power, max.	5 kW*
Average power, max.	750 W
VSWR, max.	1.2
VSWR WOW, max.	0.05
Insertion loss, max.	0.2 dB
Insertion loss WOW, max.	0.1 dB
Phase WOW, max.	2 deg.

* Conditions: Operating altitude, max. 2000 m

General mechanical data	
Rotating speed, max.	120 rpm
Life, min.	20 x 10 ⁶ revolutions
Starting torque, max.	0.2 Nm @ room temperature
Torque during rotation, max.	0.2 Nm @ room temperature
Case material	aluminum alloy
Case surface finish	chromate conversion coat
Weight, approx.	0.25 kg

General environmental conditions	
Operation	
Ambient temperature range	-40 °C ... +70 °C
Relative humidity, max.	95%
IP protection level	IP40
Storage	
Ambient temperature range	-55 °C ... +70 °C
Relative humidity, max.	95%

SINGLE CHANNEL WAVEGUIDE ROTARY JOINT

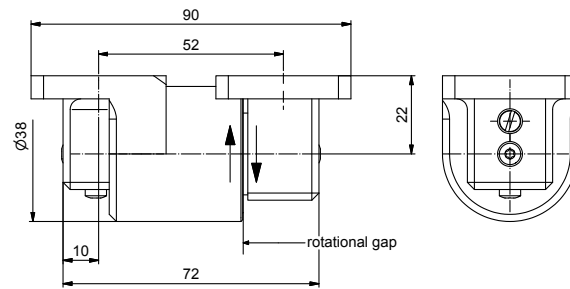

RF channel characteristics	BN 63 57 07
Interfaces	UBR120 with thread M4
Style	U
Frequency range	10.70 - 14.50 GHz
Peak power, max.	5 kW*
Average power, max.	750 W
VSWR, max.	1.2
VSWR WOW, max.	0.05
Insertion loss, max.	0.2 dB
Insertion loss WOW, max.	0.1 dB
Phase WOW, max.	2 deg.

* Conditions: Operating altitude, max. 2000 m

General mechanical data	
Differential operating pressure, nom.	2 x 10 ⁵ Pa (2 bar)
Leakage rate, max.	10 cm ³ /minute
Rotating speed, max.	120 rpm
Life, min.	20 x 10 ⁶ revolutions
Starting torque, max.	0.35 Nm @ room temperature
Torque during rotation, max.	0.30 Nm @ room temperature
Case material	aluminum alloy
Case surface finish	chromate conversion coat per MIL-C-5541
Weight, approx.	0.24 kg

General environmental conditions	
Operation	
Ambient temperature range	-40 °C ... +70 °C
Relative humidity, max.	95%
IP protection level	IP65
Storage	
Ambient temperature range	-55 °C ... +70 °C
Relative humidity, max.	95%

SINGLE CHANNEL WAVEGUIDE ROTARY JOINT

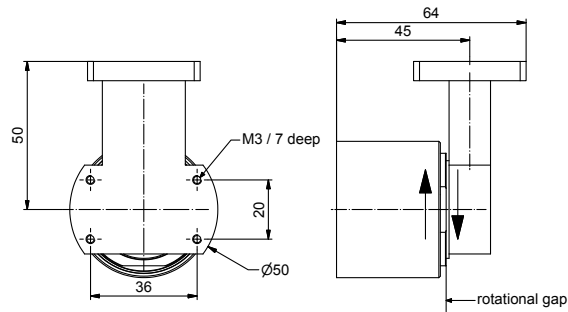

RF channel characteristics	BN 63 57 25
Interfaces	UBR120
Style	L
Frequency range	13.75 - 14.50 GHz
Peak power, max.	5 kW at sea level
Average power, max.	100 W
VSWR, max.	1.2
VSWR WOW, max.	0.1
Insertion loss, max.	0.2 dB
Insertion loss WOW, max.	0.05 dB

General mechanical data	
Rotating speed, max.	50 rpm
Life, min.	10 x 10 ⁶ revolutions
Starting torque, max.	0.25 Nm @ room temperature
Torque during rotation, max.	0.20 Nm @ room temperature
Case material	aluminum alloy
Case surface finish	chromate conversion coat per MIL-C-5541
Weight, approx.	0.3 kg

General environmental conditions	
Operation	
Ambient temperature range	-40 °C ... +70 °C
Relative humidity, max.	95%
IP protection level	IP41
Storage	
Ambient temperature range	-40 °C ... +80 °C
Relative humidity, max.	95%

SINGLE CHANNEL WAVEGUIDE ROTARY JOINT

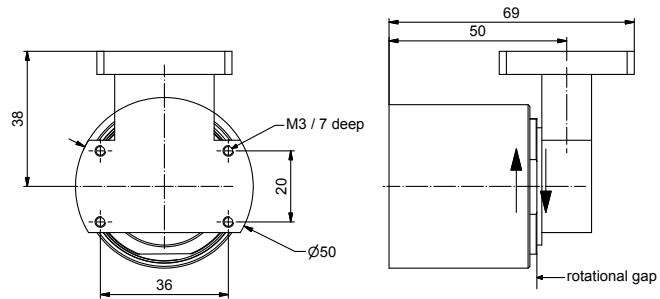

RF channel characteristics	BN 63 57 26
Interfaces	UBR120
Style	L
Frequency range	13.75 - 14.50 GHz
Peak power, max.	5 kW at sea level
Average power, max.	100 W
VSWR, max.	1.2
VSWR WOW, max.	0.1
Insertion loss, max.	0.2 dB
Insertion loss WOW, max.	0.05 dB

General mechanical data	
Differential operating pressure, nom.	2 x 10 ⁵ Pa (2.0 bar)
Leakage rate, max.	10 cm ³ /minute
Rotating speed, max.	50 rpm
Life, min.	10 x 10 ⁶ revolutions
Starting torque, max.	0.7 Nm @ room temperature
Torque during rotation, max.	0.6 Nm @ room temperature
Case material	aluminum alloy
Case surface finish	chromate conversion coat per MIL-C-5541
Weight, approx.	0.35 kg

General environmental conditions	
Operation	
Ambient temperature range	-40 °C ... +70 °C
Relative humidity, max.	95%
IP protection level	IP65
Storage	
Ambient temperature range	-40 °C ... +80 °C
Relative humidity, max.	95%

SINGLE CHANNEL WAVEGUIDE ROTARY JOINT

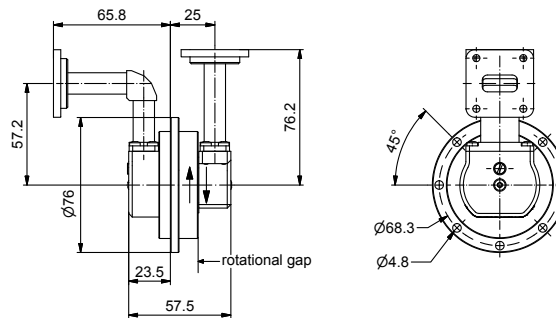

RF channel characteristics	BN 63 57 17
Interfaces	154 IEC UBR120
Style	L
Frequency range	14.0 - 14.5 GHz
Peak power, max.	5 kW*
Average power, max.	750 W
VSWR, max.	1.2
VSWR WOW, max.	0.05
Insertion loss, max.	0.2 dB
Insertion loss WOW, max.	0.1 dB
Phase WOW, max.	2 deg.

* Conditions: Operating altitude, max. 2000 m

General mechanical data	
Rotating speed, max.	120 rpm
Life, min.	20 x 10 ⁶ revolutions
Starting torque, max.	0.2 Nm @ room temperature
Torque during rotation, max.	0.2 Nm @ room temperature
Case material	aluminum alloy
Case surface finish	chromate conversion coat
Weight, approx.	0.43 kg

General environmental conditions	
Operation	
Ambient temperature range	-40 °C ... +80 °C
Relative humidity, max.	95%
IP protection level	IP40
Storage	
Ambient temperature range	-55 °C ... +80 °C
Relative humidity, max.	95%

SINGLE CHANNEL WAVEGUIDE ROTARY JOINT

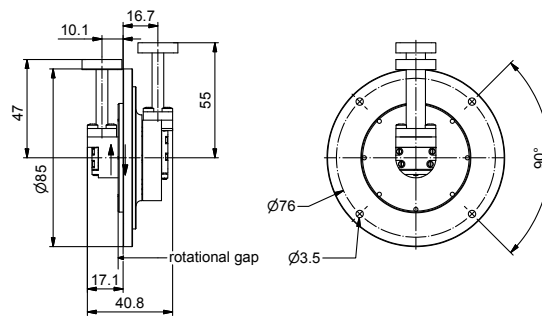

RF channel characteristics	BN 83 50 92
Interfaces	154 IEC PBR320 with thread M2.5
Style	U
Frequency range	30 - 31 GHz
Peak power, max.	10 kW*
Average power, max.	300 W
VSWR, max.	1.2
VSWR WOW, max.	0.15
Insertion loss, max.	0.25 dB
Insertion loss WOW, max.	0.05 dB

* Conditions: Operating altitude, max. 12.200 m

General mechanical data	
Rotating speed, max.	300 rpm
Life, min.	5 x 10 ⁶ revolutions
Starting torque, max.	0.12 Nm @ room temperature
Torque during rotation, max.	0.12 Nm @ room temperature
Case material	copper alloy
Case surface finish	silver plated
Weight, approx.	0.45 kg

General environmental conditions	
Operation	
Ambient temperature range	-50 °C ... +60 °C
Relative humidity, max.	95%
IP protection level	IP50
Storage	
Ambient temperature range	-50 °C ... +70 °C
Relative humidity, max.	95%

SINGLE CHANNEL WAVEGUIDE ROTARY JOINTS

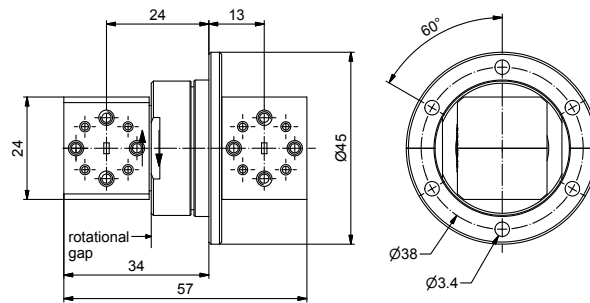

RF channel characteristics	BN 63 62 94	BN 63 62 95	BN 63 62 96	BN 63 62 97
Interface, per M3922/67-010	UG-387 / U-mod			
Style / interface in-line	U	L	L	I
Frequency range	93.0 - 95.0 GHz			
Peak power, max.	250 W*			
Average power, max.	10 W			
VSWR, max.	1.5	1.3	1.5	1.5
VSWR WOW, max.	0.2			
Insertion loss, max.	1.2 dB	0.7 dB	1.2 dB	1.2 dB
Insertion loss WOW, max.	0.2 dB	0.1 dB	0.2 dB	0.2 dB

* Conditions: Operating altitude if not pressurized, max. 3000 m; Load VSWR, max. 2

General mechanical data	
Rotating speed, max.	300 rpm
Life, min.	20 x 10 ⁶ revolutions
Starting torque, max.	0.2 Nm @ room temperature
Torque during rotation, max.	0.2 Nm @ room temperature
Case material	copper alloy
Case surface finish	gold plated
Weight, approx.	0.25 kg

General environmental conditions	
Operation	
Ambient temperature range	-40 °C ... +70 °C
Relative humidity, max.	95%
IP protection level	IP40
Storage	
Ambient temperature range	-55 °C ... +70 °C
Relative humidity, max.	95%



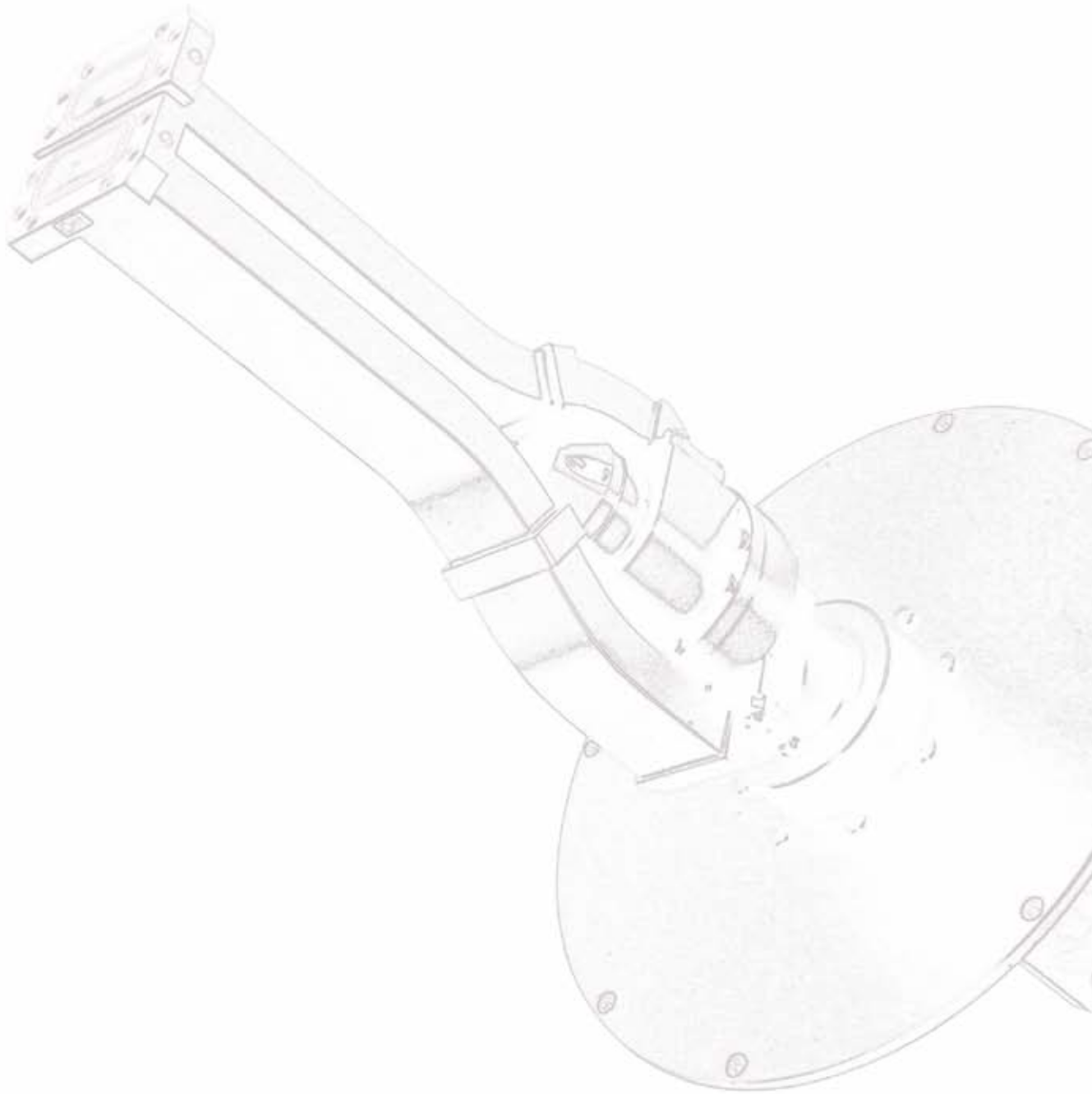

DUAL CHANNEL WAVEGUIDE ROTARY JOINTS

Most of our dual channel waveguide rotary joints are getting used in marine radar and as well in weather radar applications. Following pages show just a small selection of designs.

Part number	Number of channel	Frequency range main channel	Interface	Page
BN 63 52 40	2	9.3 - 9.5 GHz	UG 40/U, special flange	104
BN 63 52 44	2	9.3 - 9.4 GHz	CPR 90/G	105
BN 63 50 56	2	9.0 - 10.0 GHz	R100 mod.	106
BN 63 50 58	2	14.00 - 14.5 GHz	R120 special flange	107



DUAL CHANNEL WAVEGUIDE ROTARY JOINT

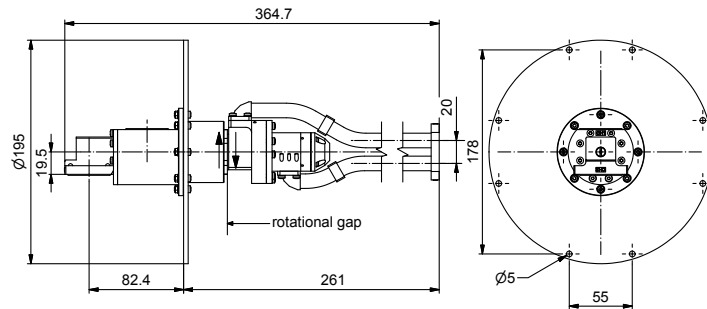

RF channel characteristics	BN 63 52 40	
Channel designation	Channel 1	Channel 2
Interfaces	Stator side: flange UG 40B/U, modified HC 4x 0.7 – 1.5 d Rotor side: special flange type (see 635240-0E)	
Style	U	U
Frequency range	9.3 - 9.5 GHz	9.3 - 9.5 GHz
Peak power, max.	10 kW	10 kW
Average power, max.	100 W	100 W
VSWR, max.	1.2	1.2
VSWR WOW, max.	0.05	0.05
Insertion loss, max.	0.25 dB	0.3 dB
Insertion loss WOW, max.	0.05 dB	0.05 dB
Isolation	60 dB	

General mechanical data	
Rotating speed, max.	60 rpm
Life, min.	120 x 10 ⁶ revolutions @ 40 rpm
Starting torque, max.	1 Nm @ room temperature
Torque during rotation, max.	1 Nm @ room temperature
Case material	aluminum alloy
Case surface finish	chromate conversion coat
Weight, approx.	2 kg

General environmental conditions	
Operation	
Ambient temperature range	-40 °C ... +70 °C
Relative humidity, max.	95%
IP protection level	IP65
Storage	
Ambient temperature range	-55 °C ... +70 °C
Relative humidity, max.	95%

DUAL CHANNEL WAVEGUIDE ROTARY JOINT

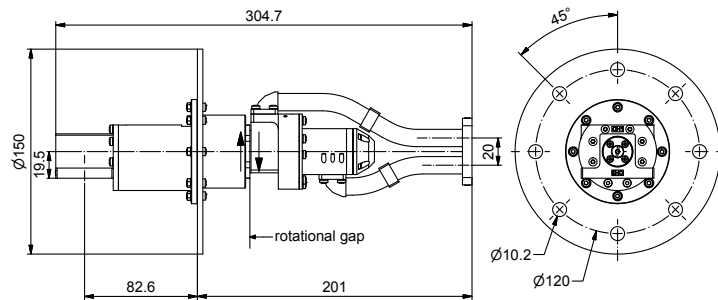

RF channel characteristics	BN 63 52 44	
Channel designation	Channel 1	Channel 2
Interfaces	CPR90/G	
Style	L	L
Frequency range	9.3 - 9.4 GHz	9.3 - 9.4 GHz
Peak power, max.	70 kW	70 kW
Average power, max.	70 W	70 W
VSWR, max.	1.2	1.2
VSWR WOW, max.	0.05	0.05
Insertion loss, max.	0.5 dB	0.5 dB
Insertion loss WOW, max.	0.05 dB	0.05 dB
Isolation	60 dB	
Phase WOW, max.	1 deg.	1 deg.

General mechanical data	
Differential operating pressure, nom.	1 x 10 ⁵ Pa (1.0 bar)
Differential operating pressure, max.	2 x 10 ⁵ Pa (2.0 bar)
Absolute operating pressure, min.	1.7 x 10 ⁵ Pa (1.7 bar)
Leakage rate, max.	20 cm ³ /minute
Rotating speed, max.	7 rpm
Life, min.	50 x 10 ⁶ revolutions
Case material	aluminum alloy
Case surface finish	painted (RAL 9005)
Weight, approx.	1.5 kg

General environmental conditions	
Operation	
Ambient temperature range	-40 °C ... +70 °C
Relative humidity, max.	95%
IP protection level	IP64
Storage	
Ambient temperature range	-45 °C ... +80 °C
Relative humidity, max.	95%

DUAL CHANNEL WAVEGUIDE / COAX ROTARY JOINT

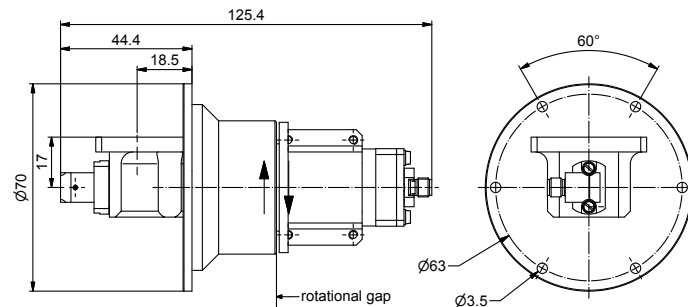

RF channel characteristics	BN 63 50 56	
	Channel 1	Channel 2
Channel designation	Channel 1	Channel 2
Interfaces	R100 mod.	3.5 mm-f (50 Ω)
Style	U	L
Frequency range	9.0 - 10 GHz	9.0 - 10 GHz
Peak power, max.	2 kW *	1 kW *
Average power, max.	200 W	0.1 W
VSWR, max.	1.2	1.35
Insertion loss, max.	0.2 dB	0.4 dB
Isolation, min.	50 dB	

* Conditions: Operating altitude if not pressurized, max. 9000 m

General mechanical data	
Differential operating pressure, nom.	0.50 x 10 ⁵ Pa (0.50 bar)
Absolute operating pressure, min.	0.32 x 10 ⁵ Pa (0.32 bar)
Rotating speed, max.	60 rpm
Life, min.	1 x 10 ⁶ revolutions
Starting torque, max.	0.20 Nm @ room temperature
Torque during rotation, max.	0.15 Nm @ room temperature
Case material	aluminum alloy
Case surface finish	chromate conversion coat
Weight, approx.	0.35 kg

General environmental conditions	
Operation	
Ambient temperature range	-40 °C ... +70 °C
Relative humidity, max.	95%
IP protection level	IP67
Storage	
Ambient temperature range	-50 °C ... +85 °C
Relative humidity, max.	95%

DUAL CHANNEL WAVEGUIDE ROTARY JOINT

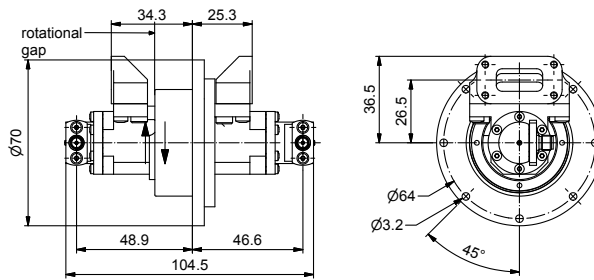

RF channel characteristics	BN 63 50 58	
Channel designation	Channel 1	Channel 2
Interfaces	R120 special flange	SMA-f (50 Ω)
Style	I	U
Frequency range	14.0 - 14.5 GHz	DC - 2.05 GHz
Peak power, max.	10 kW*	–
Average power, max.	100 W	10 W
VSWR, max.	1.2	
VSWR WOW, max.	0.1	0.05
Insertion loss, max.	0.2 dB	0.4 dB
Insertion loss WOW, max.	0.05 dB	0.1 dB
Isolation	60 dB	
Phase WOW, max.	1 deg.	1 deg.

* Conditions: Operating altitude if not pressurized, max. 1000 m

General mechanical data	
Rotating speed, max.	60 rpm
Life, min.	10 x 10 ⁶ revolutions
Torque, max.	0.20 Nm @ room temperature
Case material	aluminum alloy
Case surface finish	chromate conversion coat
Weight, approx.	0.4 kg

General environmental conditions	
Operation	
Ambient temperature range	-40 °C ... +70 °C
Relative humidity, max.	95%
IP protection level	IP64
Storage	
Ambient temperature range	-45 °C ... +80 °C
Relative humidity, max.	95%



Company: _____ Contact Name: _____

Address: _____ Phone / Fax: _____

_____ E-Mail: _____ @ _____

Your Ref: _____ Date: _____

Project / Delivery Contry: _____

Application: military use ground airborne space RF rotary joint FOJ rotary joint
 civil use naval other _____ Media rotary joint Encoder

Required Quantity: _____ Prototype _____ Serial _____ Delivery Period: _____

RF CHANNEL CHARACTERISTICS - Total number of channels: <input type="text" value="...."/>						
Channel designation	1	2	3	4	5	6
Interfaces						
Style						
Frequency range						
Peak power, max.						
Average power, max.						
VSWR, max.						
VSWR WOW, max.						
Insertion loss, max.						
Insertion loss WOW, max.						
Phase WOW, max.						
Absolute phase difference						
Isolation, min.						
DC carrying capability, max.						

GENERAL MECHANICAL DATA	
Rotating speed, max.	rpm
Life, min.	... x ... revolutions
Starting torque, max.	Nm
Torque during rotation, max.	Nm
Case material	
Case surface finish, per MIL-C-5541	
Weight, approx.	kg

GENERAL ENVIRONMENTAL CONDITIONS	
Operation	
Ambient temperature range	... °C to ... °C
Relative humidity, max.	%
IP protection level	IP..
Storage	
Ambient temperature range	... °C to ... °C
Relative humidity, max.	%

DOCUMENTS REQUIRED	
CoC according DIN 55350-18	<input type="checkbox"/>
Government Source Inspection	<input type="checkbox"/>
Environmental Test	<input type="checkbox"/>
Other	<input type="checkbox"/>
.....	



FIBER OPTIC CHANNEL CHARACTERISTICS - Number of channels: <input type="text" value="...."/>	
Interface type	
Fiber type	<input type="checkbox"/> single mode <input type="checkbox"/> multi mode <input type="checkbox"/>
Jacket	
Data transmission lines / mode	
Wavelength	
Return loss, min.	dB
Insertion loss, max.	dB
Insertion loss WOW, max.	dB
Cross talk, min.	dB
Optical power, max.	mW / dBm

MEDIA ROTARY JOINT CHARACTERISTICS	Channel LINE IN	Channel LINE OUT
Operative system pressure (kPa)		
Over pressure peak for 15 sec (kPa), max.		
Added pressure drop in both lines at flow (kPa), max.		@ liters/min
Flow rate		liters/min
Backflow leakage, max.		liters/min
Liquid/air composition*		
Nominal liquid temperature (°C)		
Liquid temperature range, min./max. (°C)		
Particle size in liquid (µm), max.		

*eg: 40% water + 60% ethylene glycol + inhibitors

DESCRIPTION OF APPLICATION:



ELECTRICAL REQUIREMENTS - Total number of ways: <input type="text" value="...."/>						
Designation of groups	A	B	C	D	E	F
Number of ways per group						
Application						
Normal current	A	A	A	A	A	A
Maximum current / period						
Voltage	V	V	V	V	V	V
Frequency	kHz	kHz	kHz	kHz	kHz	kHz
Isolation resistance / 500 V DC						
Dielectrical strength						
Resistance (End to End)						
Noise	Ω	Ω	Ω	Ω	Ω	Ω
Crosstalk						
Insertion loss	dB	dB	dB	dB	dB	dB
Impedance						
VSWR, max.						
Protection earth						
Switch-off time						

GENERAL MECHANICAL DATA	
Average rotational speed, max.	rpm
Rotating speed, max.	rpm
Turning torque static, max.	Nm
Turning torque dynamic, max.	Nm
Surface finish	

REQUIRED QUALITY DOCUMENTS	
CoC according DIN 55350-18	<input type="checkbox"/>
Government source inspection	<input type="checkbox"/>
Environmental test	<input type="checkbox"/>
Other	<input type="checkbox"/>
.....	

DIMENSIONS / LIMITATION / CONDITIONS	
Outer diameter, max.	mm
Free inner bore	<input type="checkbox"/> yes, mm <input type="checkbox"/> no
Total length	mm
Weight, max.	kg

GENERAL ENVIRONMENTAL CONDITIONS	
Isolation (per EN60529)	
Vibration / Shock / Acceleration	

LIFE TIME MAINTENANCE	
Operation time / Duty cycle (Hour per time interval)	
Life, min. x revolutions
Maintenance x revolutions
Brush change x revolutions
Warranty conditions	



TYPE OF CONNECTION				
Rotor Stator	Rotor: Connector	<input type="checkbox"/>	Stator: Connector	<input type="checkbox"/>
	Cable	<input type="checkbox"/>	Cable	<input type="checkbox"/>
	Solder terminal	<input type="checkbox"/>	Solder terminal	<input type="checkbox"/>
	Screw terminal	<input type="checkbox"/>	Screw terminal	<input type="checkbox"/>
Length of cable		m		m
Mating connectors to be supplied	<input type="checkbox"/>			

DESCRIPTION OF APPLICATION:

TECHNICAL ANNEX

GENERAL TERMS

Channel

Describes a physical transmission path having one port on the stator and one port on the rotor. Unlike in telecommunication engineering, this term does not describe a certain limited portion of the electro-magnetic spectrum when used in this context.

Contacting rotary joint

A rotary joint utilizing galvanic sliding contacts. Typically, wide-band designs are based on contacting coupling structures. Furthermore, contacting designs allow for DC transmission and can handle low frequency signals at limited space. Life is limited however (usually to some 10^6 to 10^7 revolutions) because of contact wear.

Hollow shaft module

A module with a clear inner bore along its axis of rotation. Usually hollow shaft modules are stackable to create multi channel rotary joints. The inner transmission lines of all neighboring modules are fed through the center bore.

Module

A basic rotary joint element (usually single channel). Multi channel designs are commonly comprised of several individual modules.

Non-contacting rotary joint

A rotary joint based on non-contacting coupling mechanisms like capacitive, inductive, transmission line or transformer coupling. Non-contacting rotary joints generally cover a limited bandwidth (typical relative bandwidth less than 40%; in most applications some 10 to 20%) because of frequency-dependent coupling mechanisms.

Non-contacting rotary joints offer superior product life time over contacting designs since contact wear is eliminated. Typical life figures are only limited by the bearing or sealing system and might be as high as several hundred millions of revolutions.

The transmission line coupling mechanism is usually limited to channels operating in the GHz frequency range because lower frequencies would result in large-sized coupling structures.

On-axis module (center module)

A module without a center bore. Commonly used as the final stacking element in multi channel units.

Rotary joint

A rotary transducer featuring an unlimited angle of rotation. SPINNER's design capabilities include systems for data, power and media transmission as radio frequency (RF) signals; electrical signals; fiber optical signals; electrical power and media like gases and liquids.

Rotary joints may also be equipped with further subsystems like angular encoders and revolution counters. Commonly a rotary joint is abbreviated as R/J, in case of fiber optical rotary joint as FORJ.

Rotor

Rotating portion of a rotary joint.

Slip ring

A particular variant of a contacting low frequency rotary joint, mostly equipped with a large-diameter center bore. Slip rings are based on ring and static brush systems and commonly used for power and signal transmission.

Slip ring assemblies for big multi channel rotary joints may feature some 100 ways and are often used to accommodate the (smaller) RF subsystems which are nested inside the slip ring's center bore.

Stator

Static portion of a rotary joint. Stators are not necessarily characterized by a mounting flange.

Swivel joint

Any rotary transducer featuring a limited angle of rotation.

RF CHANNEL CHARACTERISTICS

Attenuation and amplification

Attenuation is defined as the reduction of the transmitted energy of a signal in the course of a transmission link. Thus attenuation is negative amplification. Attenuation and amplification are usually specified in dB (decibel). Specifications in dB are „relative levels“. Here the notion „level“ means the comparison between a measured value and a reference value: The relative level of a transmission link is defined as follows: The level at a reference point, e. g. at the feeding point, is defined as 0 dB, regardless of the actual absolute level. The relative level at the end of the link is derived by adding the reference level and all transmission parameters of the elements of the transmission link (positive for amplifiers, negative for attenuation links).

Average power

Maximum permissible long term ("continuous wave" or CW) power which a component can handle safely without internal overheating.

During operation ohmic and dielectric losses generate heat inside the rotary joint. Hence, the maximum permissible average power is frequency-dependent.

The relation between heat generation and heat dissipation (by metallic feeder waveguides, casing, mounting flanges and air convection) determines the actual CW power that may be applied over a long period of time while still ensuring safe internal operating temperatures for all critical parts. Average power handling may be increased by additional forced cooling (air or water) and use of advanced materials or designs. Excessive ambient temperatures will degrade the average power capability respectively.

TECHNICAL ANNEX

DC carrying capability

Naturally, this parameter is only specified for contacting rotary joints. It describes the maximum DC current that can be safely transmitted over a rotary joint. This may be of relevance for applications where biased electronic assemblies are located close to the antenna. If high direct (or low frequency) current transfer is demanded, the RF power capability is usually compromised.

Because of the delicate nature of several contact parts inside most typical RF rotary joints the DC carrying capability is commonly limited to currents of a few amperes and to low voltages.

If higher DC or low frequency AC power transmission capabilities are desired, SPINNER encourages the use of slip ring assemblies particularly designed for this purpose.

Frequency range

Portion of the electromagnetic spectrum which a component has been designed for and within which the respective specification is valid. SPINNER offers designs for the entire frequency range between DC and the millimeter wave range.

Insertion loss

Attenuation of a signal being passed through a device within the signal path. Insertion loss a_i is usually expressed as the logarithmic ratio (in dB) between incident power P_{in} and output power P_{out} :

$$a_i = 10 \text{ dB} \cdot \log P_{in} / P_{out}$$

Internal transmission line structures, feeder waveguides or cables cause ohmic, dielectric and reflection losses. The dissipated energy results in heat generation and limits the maximum permissible long-term power rating. Generally speaking, long designs suffer from higher insertion loss than shorter ones and waveguide designs are usually superior to coaxial designs. Whenever there is a choice, the system waveguide size should be chosen as big as possible because of increased waveguide losses in the lower portion of their operating band.

Insertion loss is somewhat temperature-dependent. SPINNER would like to point out that any insertion loss figures stated in SPINNER data sheets hold true for the entire specified range of operating temperatures and the nominal operating power.

Most waveguide rotary joints feature insertion loss values in the 0.1 dB to 0.5 dB range, and so do usual coaxial designs without cables. Large multi channel rotary joints contain additional internal cables which may cause significant additional losses.

Any "insertion loss, max." figures given in SPINNER data sheets are worst-case values over the entire temperature range and rotation.

Insertion loss difference absolute

This parameter is only defined for two channels operating in the same frequency range. It describes the difference between their insertion loss figures at a certain frequency and at an identical rotational angle θ .

"Absolute insertion loss difference, max.", as given in SPINNER datasheets, describes the worst-case value over the rotational angle θ at the frequency f_{ILD} which delivers the maximum difference within the operating frequency band:

$$ILD_{max} = | a_{i,CH1}(\theta) - a_{i,CH2}(\theta) | @ f_{ILD}; \theta_{ILD}$$

If required careful tuning of the internal cable lengths enables insertion loss matching of channels within 0.1 to 0.2 dB (for coaxial multi channel rotary joints).

Insertion loss tracking over rotation

Insertion loss tracking is only defined for two channels operating in the same frequency range. It describes their insertion loss synchronism over rotation.

Two modules, each suffering from high insertion loss variation over rotation, can still result in a dual channel rotary joint with good insertion loss tracking since the two individual variations may be equal and therefore cancel out if combined properly.

This parameter could also be expressed as "variation of insertion loss difference over rotation".

"Insertion loss tracking, max.", as given in SPINNER datasheets, describes the worst-case value over the rotational angle θ at the frequency f_{ILD} which delivers the maximum variation of insertion loss difference within the operating frequency band:

$$ILT_{max} = | ILD_{max}(\theta) - ILD_{min}(\theta) | @ f_{ILT}; \theta_{ILT}$$

Insertion loss variation over rotation

Sometimes also named "insertion loss WOW", this parameter describes how much insertion loss changes over a full rotation at the "worst" frequency within the specified frequency range. For most technical applications this parameter is of higher relevance than VSWR variation.

"Insertion loss variation over rotation" is defined as the difference between the pair of insertion loss values ($a_{i,max}$ and $a_{i,min}$) measured at the frequency point f_{iL} which features the highest insertion loss variation over the rotational angle θ :

$$\Delta a_{i,max} = a_{i,max}(\theta) - a_{i,min}(\theta) @ f_{iL}$$

This definition of insertion loss variation can be depicted as the maximum distance between the two insertion loss plots taken at their "worst" and "best" rotational angles. Insertion loss variation is mostly a footprint of VSWR variation which in turn causes varying reflection losses.

Any "insertion loss variation over rotation, max." figures given in SPINNER data sheets are worst-case values (typically between 0.05 dB and 0.2 dB) and do already include a safety margin to consider instabilities of moved measurement lines.

TECHNICAL ANNEX

Interface orientation

Describes the basic style of a rotary joint depending on the orientation of both interfaces (rotor and stator).

Several waveguide designs may actually only be realized as "U" styles and must be adapted to the desired style using external waveguides.

- I-style: Both interfaces in line with the rotational axis.
- U-style: Both interfaces perpendicular to the rotational axis.
- L-style: Special arrangement of interface orientation, one interface is perpendicular to the rotational axis, the other interface is in line with the rotating axis.

Interface type

Generally, SPINNER RF rotary joints come with either waveguide or coaxial interfaces. The appropriate choice depends on application, frequency range and power rating requirements. Most waveguide rotary joints feature standardized waveguide interfaces according to IEC-154, MIL-DTL-3922 or EIA-RS 271, which may be either of the plain or choke type. Grooves on sealed flanges in combination with gaskets allow for pressurization and provide protection against ingress of dirt and moisture. Internal corners of waveguide interfaces are sometimes rounded for manufacturing reasons. These rounded corners have been designed carefully and thus are fully electrically compensated when mated to "real" rectangular standard waveguides.

Consequently, RF performance will not be compromised at all by the rounding. Coaxial designs are usually equipped with precision coaxial connectors according to IEEE Std 287-2007.

Isolation

Describes the crosstalk between two channels.

The amount of RF energy leaking from one channel to a second one is usually expressed as insertion loss (in dB) between one port of the first channel and another port of the second channel while all remaining ports are properly terminated. Depending on the choice of ports two different isolation types must be considered: Forward and reverse isolation.

All isolation values given by SPINNER represent worst-case values including both forward and reverse isolation. Typical values are some 50 to 70 dB while particular designs, especially waveguide rotary joints designed for exceptionally high power, allow for isolation values around 100 dB.

Peak power

Maximum permissible short term power which a component can handle safely without internal arcing or breakdown.

In contrast to "instantaneous values", this term refers to short-term RMS values within the pulse duration. Usual pulse durations are in the μs range. It should be pointed out that the actual peak power capability depends considerably on parameters such as absolute air pressure inside the component, load VSWR, temperature, pulse duration and pulse repetition time. Specifying the required operating pressure for a given peak power is of paramount importance. While low ambient air pressure will degrade the peak power capability, it can be massively enhanced

by a pressurization of all electrically stressed components with dry compressed air or particular insulation gases like SF₆. If space use is intended, a different vacuum discharge mechanism called "multipactor discharge" becomes crucial.

SPINNER datasheets provide all necessary information about these limiting conditions. Depending on the connector size, coaxial rotary joints usually feature peak power figures in the 1 to 10 kW range while typical values for unpressurized waveguide rotary joints might be as high as 10 kW to 1 MW (also depending on waveguide size). Peak power level is limited to the air pressure at sea level if not otherwise indicated.

Phase difference absolute

Like insertion loss difference, this parameter is only defined for two channels operating in the same frequency range. It describes the difference between their insertion phases at a certain frequency and at an identical rotational angle θ .

"Absolute phase difference, max.", as given in SPINNER datasheets, describes the worst-case value over the rotational angle θ at the frequency f_{PD} which delivers the maximum difference within the operating frequency band:

$$PD_{max} = |\varphi_{i,CH1}(\theta) - \varphi_{i,CH2}(\theta)| @ f_{PD}; \theta_{PD}$$

If required careful tuning of the internal cable lengths enables phase matching of channels within a few degrees (for coaxial multi channel designs, depending on wavelength).

Phase tracking over rotation

Phase tracking is only defined for two channels operating in the same frequency range. It describes their phase synchronism over rotation. Two modules, each suffering from high phase variation over rotation, can still result in a dual channel rotary joint with good phase tracking since the two individual variations may be equal and therefore cancel out if combined properly.

This parameter could also be expressed as "variation of phase difference over rotation".

"Phase tracking, max.", as given in SPINNER datasheets, describes the worst-case value over the rotational angle θ at the frequency f_{PT} which delivers the maximum variation of the phase difference within the operating frequency band:

$$PT_{max} = PD_{max}(\theta) - PD_{min}(\theta) @ f_{PT}; \theta_{PT}$$

Some applications, for example secondary surveillance radar (SSR), require well matched rotary joint channels (both insertion loss and phase) along with tracking requirements.

Phase variation over rotation

Phase variation over rotation or "phase WOW" describes how much the insertion phase of a rotary joint changes over a full rotation at the "worst" frequency within the specified frequency range. This parameter indicates a variation of the effective electric length. Along with insertion loss variation over rotation it is of higher relevance for most technical applications than VSWR variation.

TECHNICAL ANNEX

"Phase variation over rotation" is defined as the difference between the pair of insertion phase values ($\varphi_{i,max}$ and $\varphi_{i,min}$) measured at the frequency point f_{PV} which features the highest insertion loss variation over the rotational angle θ :

$$\Delta \varphi_{i,max} = \varphi_{i,max}(\theta) - \varphi_{i,min}(\theta) @ f_{PV}$$

This definition of insertion phase variation can be depicted as the maximum distance between the two insertion phase plots taken at their "worst" and "best" rotational angles. Any "phase variation over rotation, max." figures given in SPINNER data sheets are worst-case values (typically of the order of 0.5 to 5 degree) and do already include a safety margin to consider instabilities of moved measurement lines.

Return loss

Alternative representation of VSWR, describes the logarithmic ratio (in dB) between incident power P_{in} and reflected power P_r at a component's port:

$$a_r = 10 \text{ dB} \cdot \log P_{in}/P_r$$

The return loss a_r is infinite in the perfectly matched case and zero at total reflection. A high return loss figure is desirable and indicates a well matched component. Return loss values usually range from 10 dB to 40 dB.

Values, maximum and minimum

Maximum or minimum values represent guaranteed limit values which are not exceeded at any time or under any condition specified in the data sheet. Usually there is a safety margin between these guaranteed maximum limits and the values typically measured at room temperature.

Values, typical

In many cases SPINNER specifies both maximum and typical values.

Typical values are given whenever useful for a more realistic description of the performance. These values are typically observed on the majority of a production batch when measured under standard conditions. SPINNER does not guarantee these "typical values" however.

VSWR / reflection factor

When an electrical line is terminated by a load with its characteristic impedance a signal transmitted to the line is fully absorbed by the matching load. However, if the impedance of the termination differs from the characteristic impedance of the line the wave will be reflected more or less strongly. The reflection factor r is related to the complex impedance of the line, Z_0 , and the complex terminating impedance, Z :

$$r = \frac{Z - Z_0}{Z + Z_0}$$

The waves continuing along the line and reflected waves are overlaying to form standing waves. The amplitude relationship between the largest and the smallest voltage on a loss-free line is defined as the VSWR (Voltage Standing Wave Ratio):

$$VSWR = \frac{1 + |r|}{1 - |r|}$$

The reflection factor is often specified as the logarithmic value of the return loss:

$$\alpha = -20 \log(r) \text{ dB}$$

VSWR variation over rotation

Sometimes also named "VSWR WOW", this parameter describes how much VSWR changes over a full rotation at the "worst" frequency within the specified frequency range. SPINNER defines "VSWR variation over rotation" as the difference between the pair of VSWR values ($VSWR_{max}$ and $VSWR_{min}$) measured at the frequency point f_{VSWR} which features the highest VSWR variation over the rotational angle θ :

$$\Delta VSWR_{max} = VSWR_{max}(\theta) - VSWR_{min}(\theta) @ f_{VSWR}$$

This definition of VSWR variation can be depicted as the maximum distance between the two VSWR plots taken at their "worst" and "best" rotational angles. Common values are between 0.02 and 0.2.

Please note that alternative definitions exist for this parameter. The most popular one is the ratio between $VSWR_{max}$ and $VSWR_{min}$ and leads to values greater than one. Unless otherwise required by customers, SPINNER does not use these definitions.

GENERAL MECHANICAL DATA

Case material

The case material is the material of the housings and main flanges. For the internal design also other materials are used. Typical materials are aluminum alloy, copper alloy or stainless steel.

Case surface finish

The case surface finish is the surface treatment of the housings and main flanges. For the internal design also other surface treatments are used. Some joints do not have any surface treatments, other typical treatments are chromate conversion coat per MIL-DTL-5541 (e.g. Surtech 650), silver plated or painted (e.g. two-component paints, PU-based, color according to RAL or other specifications).

Interface loads

The interface loads coming from the installation of the rotary joint will have an effect on the bearing design. SPINNER rotary joints usually are not designed to with stand external forces; which means that no or no significant loads are allowed.

Leakage rate

Leakage rate for pressurized wave guides valid for the indicated operating ambient temperature range. Usually indicated as maximum value valid at the indicated nominal differential pressure.



TECHNICAL ANNEX

Life time

Life time is usually indicated in number of revolutions. Life time is limited by the type (contacting) of transmission as well as by bearings and dynamic seals. The life time can be extended by dedicated maintenance tasks, available for some products.

Marking

Marking or labeling of the rotary joint. Typical solutions are adhesive label, riveted label, laser engraving, engraving or stamping.

Operating pressure absolute

Absolute pressure within the RF part of the rotary joint indicated in MPa and in bar. "Absolute operating pressure, min.", as given in SPINNER datasheets, describes the minimum pressure to be maintained in all operating conditions to ensure the peak power capability of the rotary joint. Depending on the type of insulating gas different minimum pressures need to be maintained.

Operating pressure differential

Differential pressure between pressurized area within the RF part and environment indicated in MPa (10⁶ Pa) and in bar. "Differential operating pressure, max.", as given in SPINNER datasheets, is valid for the complete operating ambient temperature range. The term "Differential operating pressure, nominal" describes the recommended operating condition.

Rotating speed

Rotational speed in rpm. Usually indicated as nominal and maximum speed.

Torque

The torque of a rotary joint gives the mechanical resistance during start up or turning. Usually these two values are indicated in Nm for room temperature and for the minimum specified operating ambient temperature. If no temperature is indicated the torque is defined at room temperature. The room temperature is defined to 20 °C ±5 °C. Torque values for other temperatures can be given upon request.

Weight

Weight of rotary joint assembly without mounting screws and protective packing.

GENERAL ENVIRONMENTAL CHARACTERISTICS

Ambient temperature range

Temperature range of the environment in °C. Typically indicated for operating and for storage condition. If not otherwise indicated SPINNER assumes that no heat from external sources is introduced into the rotary joint.

Application

The application indicates the general environment of the installed rotary joint. The application is typically defined as airborne plane, airborne helicopter, ground fixed, ground mobile, shipboard, submarine, or satellite according to MIL-HDBK-217.

Degree of Protection and IP Classification

All IP classes in this catalogue are given in accordance to DIN EN 60529. Standard DIN EN 60529:1991 defines the protection ratings for the housings of electrical appliances. The given IP classes are valid for all installation directions if not indicated. To achieve the appropriate IP class the rotary joint must be installed correctly and fitted with appropriate gasket of connected appropriate.

The IP code is used for specifying the protection rating of a housing, e. g.:

IP23CH; IP = International Protection (Ingress Protection)

IP 2 3 C H

0-6 or X – against ingress of solid objects	
0 no special protection	
1 ≥ 50.0 mm ø	4 ≥ 1.0 mm ø
2 ≥ 12.5 mm ø	5 dust protection
3 ≥ 2.5 mm ø	6 dust tight
X replaces numeral if not applicable	

IP 2 3 C H

0-8 or X – against ingress of water	
0 no special protection	
1 vertically dripping	5 jetting
2 dripping (15° tilted)	6 powerful jetting
3 spraying	7 temporary immersion
4 splashing	8 continuous immersion
X replaces numeral if not applicable	

IP 2 3 C H

optional – A,B,C,D – against access to hazardous parts	
A	back of hand
B	finger
C	tool
D	wire

IP 2 3 C H

optional – H, M, S, W – supplementary information specific for:	
H	high voltage equipment
M	motion during water test
S	stationary during water test
W	weather conditions

Fungus

Information for the compliance demonstration according to MIL-STD-810G, Method 508 "Fungus".

Icing/Freezing Rain

Information for the compliance demonstration according to MIL-STD-810G, Method 521 "Icing/Freezing Rain".



TECHNICAL ANNEX

Rain

Information for the compliance demonstration according to MIL-STD-810G, Method 506 “Rain”.

Relative humidity

The ratio of the actual vapor pressure of the air to the saturation vapor pressure in %. Typically indicated as a maximum value, valid for the complete temperature range. It must be ensured that condensing will not appear.

Sand and Dust

Information for the compliance demonstration according to MIL-STD-810G, Method 510 “Dust”.

Salt fog

Information for the compliance demonstration according to MIL-STD-810G, Method 509 “Salt Fog”.

Shock

Information for the compliance demonstration according to MIL-STD-810G, Method 516 “Shock”.

Vibration

Information for the compliance demonstration according to MIL-STD-810G, Method 514 “Vibration”.

UNIT CONVERSION

Barometric formula (Atmospheric Pressure versus Altitude)

Atmospheric pressure $\frac{p_h}{Pa}$	$p_h = 1013.25hPa \left(1 - \frac{0.0065 \cdot h}{288.15m}\right)^{5.255}$
Altitude $\frac{h}{m}$	$h = \frac{\left(1 - \left(\frac{p_h}{1013.25hPa}\right)^{\frac{1}{5.255}}\right) \cdot 288.15}{0.0065} m$

Conditions:

- Standard temperature lapse rate: 0.0065 K·m⁻¹
- Standard temperature (sea level): 15 °C = 288.15 K
- Static pressure (sea level): 1013.25 hPa
- Gravitational acceleration: 9.807 m·s⁻²
- Molar mass of Earth's air: 0.02896 kg/mol
- Universal gas constant for air: 8.314 J·(K·mol)⁻¹

High (m)	Pressure (hPa)	High (m)	Pressure (hPa)
0	1013.25	4000	616.45
500	954.61	4500	577.33
1000	898.76	5000	540.25
1500	845.58	6000	471.87
2000	794.98	7000	410.66
2500	746.86	8000	356.06
3000	701.12	9000	307.48
3500	657.68	10000	264.42

Force

	Newton (N)	Pound-force (lbf)
1 N	1.0	224.8 · 10 ⁻³
1 lbf	4.448	1.0

Torque

	Newton meter (Nm)	Pound-force foot (lbf-ft)	Ounce-force inch (ozf-in)	Pound-force inch (lbf-in)
1 Nm	1.0	0.738	141.6	8.851
1 lbf-ft	1.356	1.0	192.0	12.0
1 ozf-in	7.062 · 10 ⁻³	5.208 · 10 ⁻³	1.0	62.5 · 10 ⁻³
1 lbf-in	0.113	83.333 · 10 ⁻³	16.0	1.0

Leak rate and mass flow rate

	Millibar liter per second (T_n) *	Cubic centimeter per second (T_n, p_n)	Pascal liter per second (T_n)	Torr liter per second (T_n)	Kilogram per hour x air (20 °C)	Mole per second
1 $\frac{mbar \cdot l}{s}$	$1 \frac{mbar \cdot l}{s} (T_n)$	$0.9869 \frac{cm^3}{s} (T_n, p_n)$	$100 \frac{Pa \cdot l}{s} (T_n)$	$0.75 \frac{Torr \cdot l}{s} (T_n)$	$4.3 \cdot 10^{-3} \frac{kg}{h} \text{ air}(20 \text{ °C})$	$4.41 \cdot 10^{-5} \frac{mol}{s}$
1 $\frac{cm^3}{s} (T_n, p_n)$	$1.01 \frac{mbar \cdot l}{s} (T_n)$	$1 \frac{cm^3}{s} (T_n, p_n)$	$101 \frac{Pa \cdot l}{s} (T_n)$	$0.76 \frac{Torr \cdot l}{s} (T_n)$	$4.3 \cdot 10^{-3} \frac{kg}{h} \text{ air}(20 \text{ °C})$	$4.45 \cdot 10^{-5} \frac{mol}{s}$
1 $\frac{Pa \cdot l}{s} (T_n)$	$1 \cdot 10^{-2} \frac{mbar \cdot l}{s} (T_n)$	$\sim 1 \cdot 10^{-2} \frac{cm^3}{s} (T_n, p_n)$	$1 \frac{Pa \cdot l}{s} (T_n)$	$7.5 \cdot 10^{-3} \frac{Torr \cdot l}{s} (T_n)$	$4.3 \cdot 10^{-3} \frac{kg}{h} \text{ air}(20 \text{ °C})$	$4.41 \cdot 10^{-7} \frac{mol}{s}$
1 $\frac{Torr \cdot l}{s} (T_n)$	$1.33 \frac{mbar \cdot l}{s} (T_n)$	$1.32 \frac{cm^3}{s} (T_n, p_n)$	$133 \frac{Pa \cdot l}{s} (T_n)$	$1 \frac{Torr \cdot l}{s} (T_n)$	$5.7 \cdot 10^{-3} \frac{kg}{h} \text{ air}(20 \text{ °C})$	$5.87 \cdot 10^{-5} \frac{mol}{s}$
1 $\frac{kg}{h} \text{ air}(20 \text{ °C})$	$230 \frac{mbar \cdot l}{s} (T_n)$	$230 \frac{cm^3}{s} (T_n, p_n)$	$2.3 \cdot 10^4 \frac{Pa \cdot l}{s} (T_n)$	$175 \frac{Torr \cdot l}{s} (T_n)$	$1 \frac{kg}{h} \text{ air}(20 \text{ °C})$	$1.01 \cdot 10^{-2} \frac{mol}{s}$
1 $\frac{mol}{s}$	$2.27 \cdot 10^4 \frac{mbar \cdot l}{s} (T_n)$	$2.25 \cdot 10^4 \frac{cm^3}{s} (T_n, p_n)$	$2.26 \cdot 10^6 \frac{Pa \cdot l}{s} (T_n)$	$1.7 \cdot 10^4 \frac{Torr \cdot l}{s} (T_n)$	$99 \frac{kg}{h} \text{ air}(20 \text{ °C})$	$1 \frac{mol}{s}$

* 1 mbar·l·s⁻¹ (T_n) equates to 0.9869 cm³ of an ideal gas in standard reference conditions; 1 mbar·l·s⁻¹ (T_n) = 4.41·10⁻⁵ mol s⁻¹
 Standard reference conditions: T_n = 0 °C, p_n = 1013.25 mbar

$$\frac{p \cdot V}{T} = const$$



TECHNICAL ANNEX

Length

	Meter	Millimeter	Inch	Mil	Foot	Yard	Mile*
1 m	1.0	1000.0	39.37	39370.0	3.2808	1.0936	621.371 x 10 ⁻⁶
1 mm	0.001	1.0	0.03937	39.37	3.281 x 10 ⁻³	1.0936 x 10 ⁻³	621.371 x 10 ⁻⁹
1 in	25.4 x 10 ⁻³	25.4	1.0	1000.0	1/12.0	1/36	15.783 x 10 ⁻⁶
1 mil	25.4 x 10 ⁻⁶	25.4 x 10 ⁻³	0.001	1.0	1/12000.0	1/36000	15.783 x 10 ⁻⁹
1 ft	0.3048	304.8	12.0	12000.0	1.0	1/3	189.394 x 10 ⁻⁶
1 yd	0.9144	914.4	36.0	36000.0	3.0	1.0	568.182 x 10 ⁻⁶
1 mi	1609.344	1609344.0	63360.0	63.36 x 10 ⁻⁶	5280.0	1760.0	1.0

* 1 mile (mi) ≠ 1 nautical mile, 1 nautical mile = 1852 meter
 was adopted by the First International Extraordinary Hydrographic Conference, Monaco, 1929, under the name "International nautical mile"

Mass

	Kilogram	Gram	Ounce	Pound
1 kg	1.0	1000.0	35.27	2.205
1 g	0.001	1.0	35.27 x 10 ⁻³	2.205 x 10 ⁻³
1 oz	28.35 x 10 ⁻³	28.35	1.0	1/16
1 lb	453.6 x 10 ⁻³	453.6	16.0	1.0

Pressure

	Pascal (Pa)	Bar	Pound-force per square inch (psi)
1 Pa	1.0	10 x 10 ⁻⁶	0.145 x 10 ⁻³
1 bar	0.1 x 10 ⁶	1.0	14.5
1 psi	6.895 x 10 ³	68.95 x 10 ⁻³	10.0

Temperature

to from	degree Celsius (°C)	Kelvin (K)	degree Fahrenheit (°F)
$\frac{T}{^{\circ}\text{C}}$	$= \frac{T}{^{\circ}\text{C}}$	$= \frac{T}{\text{K}} - 273.15$	$= (\frac{T}{^{\circ}\text{F}} - 32) \cdot \frac{5}{9}$
$\frac{T}{\text{K}}$	$= \frac{T}{^{\circ}\text{C}} + 273.15$	$= \frac{T}{\text{K}}$	$= (\frac{T}{^{\circ}\text{F}} + 459.67) \cdot \frac{5}{9}$
$\frac{T}{^{\circ}\text{F}}$	$= \frac{T}{^{\circ}\text{C}} \cdot 1.8 + 32$	$= \frac{T}{\text{K}} \cdot 1.8 - 459.67$	$= \frac{T}{^{\circ}\text{F}}$

TECHNICAL ANNEX

Translation dBm into Watt

+90 dBm	1.000 000 W	10^6	1 Megawatt
+80 dBm	100.000 W	10^5	100 Kilowatt
+70 dBm	10.000 W	10^4	10 Kilowatt
+60 dBm	1.000 W	10^3	1 Kilowatt
+50 dBm	100 W	10^2	100 Watt
+40 dBm	10 W	10^1	10 Watt
+30 dBm	1 W	10^0	1 Watt
+20 dBm	0.1 W	10^{-1}	100 Milliwatt
+10 dBm	0.01 W	10^{-2}	10 Milliwatt
0 dBm	0.001 W	10^{-3}	1 Milliwatt
-10 dBm	0.000 1 W	10^{-4}	100 Microwatt
-20 dBm	0.000 01 W	10^{-5}	10 Microwatt
-30 dBm	0.000 001 W	10^{-6}	1 Microwatt
-40 dBm	0.000 000 1 W	10^{-7}	100 Nanowatt
-50 dBm	0.000 000 01 W	10^{-8}	10 Nanowatt
-60 dBm	0.000 000 001 W	10^{-9}	1 Nanowatt

Torque

	Newton meter (Nm)	Pound-force foot (lbf-ft)	Ounce-force inch (ozf-in)	Pound-force inch (lbf-in)
1 Nm	1.0	0.738	141.6	8.851
1 lbf-ft	1.356	1.0	192.0	12.0
1 ozf-in	$7.062 \cdot 10^{-3}$	$5.208 \cdot 10^{-3}$	1.0	$62.5 \cdot 10^{-3}$
1 lbf-in	0.113	$83.333 \cdot 10^{-3}$	16.0	1.0

Volume (fluid)

	Cubic meter (m ³)	Liter* (l)	Gallon, U.S. (gal)	Cubic inch (in ³)	Pint, U.S. liquid (pt)
1 m³	1.0	1000	264.2	61024	2113
1 l	10^{-3}	1	0.264	61.02	2.113
1 gal	3.785×10^{-3}	3.785	1	231	8
1 in³	16.39×10^{-6}	16.39×10^{-3}	4.329×10^{-3}	1	34.63×10^{-3}
1 liq pt	473.2×10^{-6}	0.4732	1/8	28.875	1

* In 1964 the General Conference on Weights and Measures reestablished the name "liter" as a special name for the cubic decimeter. Between 1901 and 1964 the liter was slightly larger (1.000 028 dm³); when one uses high-accuracy volume data of that time, this fact must be kept in mind. The recommended symbol for the liter in the United States is L.

TECHNICAL ANNEX

Waveguide designations			Internal dimensions		Frequency		Band	
IEC ¹	EIA ²	UK ³	Metric ¹ mm	Imperial ¹ inches	Nominal range ¹ GHz	TE ₁₀ cut-off ⁴ GHz	Most common use	Other common use
R 3	WR 2300	WG 00	584.20 x 292.10	23.000 x 11.500	0.32 - 0.49	0.257	-	-
R 4	WR 2100	WG 0	533.40 x 266.70	21.000 x 10.500	0.35 - 0.53	0.281	-	-
R 5	WR 1800	WG 1	457.20 x 228.60	18.000 x 9.000	0.41 - 0.62	0.328	-	-
R 6	WR 1500	WG 2	381.00 x 190.50	15.000 x 7.500	0.49 - 0.75	0.393	-	-
R 8	WR 1150	WG 3	292.10 x 146.05	11.500 x 5.750	0.64 - 0.98	0.513	-	-
R 9	WR 975	WG 4	247.65 x 123.82	9.750 x 4.875	0.76 - 1.15	0.605	-	-
R 12	WR 770	WG 5	195.58 x 97.79	7.700 x 3.850	0.96 - 1.46	0.766	-	-
R 14	WR 650	WG 6	165.10 x 82.55	6.500 x 3.250	1.13 - 1.73	0.908	L	-
R 18	WR 510	WG 7	129.54 x 64.77	5.100 x 2.550	1.45 - 2.20	1.157	-	-
R 22	WR 430	WG 8	109.22 x 54.61	4.300 x 2.150	1.72 - 2.61	1.372	-	Ls, R
R 26	WR 340	WG 9A	86.36 x 43.18	3.400 x 1.700	2.17 - 3.30	1.736	-	-
R 32	WR 284	WG 10	72.14 x 34.04	2.840 x 1.340	2.60 - 3.95	2.078	S	-
R 40	WR 229	WG 11A	58.17 x 29.08	2.290 x 1.145	3.22 - 4.90	2.577	-	-
R 48	WR 187	WG 12	47.549 x 22.149	1.872 x 0.872	3.94 - 5.99	3.152	C	G
R 58	WR 159	WG 13	40.386 x 20.193	1.590 x 0.795	4.64 - 7.05	3.712	-	C
R 70	WR 137	WG 14	34.849 x 15.799	1.372 x 0.622	5.38 - 8.17	4.301	-	Xn, J
R 84	WR 112	WG 15	28.499 x 12.624	1.122 x 0.497	6.57 - 9.99	5.260	-	Xb, H
R 100	WR 90	WG 16	22.860 x 10.160	0.900 x 0.400	8.20 - 12.5	6.557	X	-
R 120	WR 75	WG 17	19.050 x 9.525	0.750 x 0.375	9.84 - 15.0	7.869	-	M
R 140	WR 62	WG 18	15.799 x 7.899	0.622 x 0.311	11.9 - 18.0	9.488	Ku	P
R 180	WR 51	WG 19	12.954 x 6.477	0.510 x 0.255	14.5 - 22.0	11.571	-	N
R 220	WR 42	WG 20	10.668 x 4.318	0.420 x 0.170	17.6 - 26.7	14.051	K	-
R 260	WR 34	WG 21	8.636 x 4.318	0.340 x 0.170	21.7 - 33.0	17.357	-	-
R 320	WR 28	WG 22	7.112 x 3.556	0.280 x 0.140	26.3 - 40.0	21.077	Ka	R
R 400	WR 22	WG 23	5.690 x 2.845	0.224 x 0.112	32.9 - 50.1	26.344	Q	-
R 500	WR 19	WG 24	4.775 x 2.388	0.188 x 0.094	39.2 - 59.6	31.392	U	-
R 620	WR 15	WG 25	3.759 x 1.880	0.148 x 0.074	49.8 - 75.8	39.877	V	-
R 740	WR 12	WG 26	3.099 x 1.549	0.122 x 0.061	60.5 - 91.9	48.372	E	-
R 900	WR 10	WG 27	2.540 x 1.270	0.100 x 0.050	73.8 - 112.0	59.014	W	-
R 1200	WR 8	WG 28	2.032 x 1.016	0.080 x 0.040	92.2 - 140.0	73.768	F	-
R 1400	WR 7 ⁵ (WR 6.5)	WG 29	1.6510 x 0.8255	0.0650 x 0.0325	113.0 - 1730	90.791	D	-
R 1800	WR 5 (WR 5.1)	WG 30	1.2954 x 0.6477	0.0510 x 0.0255	145.0 - 220.0	115.71	G	-
R 2200	WR 4 (WR 4.3)	WG 31	1.0922 x 0.5461	0.0430 x 0.0215	172.0 - 261.0	137.24	-	-
R 2600	WR 3 (WR 3.4)	WG 32	0.8636 x 0.4318	0.0340 x 0.0170	217.0 - 330.0	173.57	-	-

¹ IEC 153-2, Hollow metallic waveguides, Part 2: Relevant specifications for ordinary rectangular waveguides, Standard of the International Electrotechnical Commission, 1974

² EIA RS-261-B, Rectangular Waveguides (WR 3 to WR 2300), Standard of the Electronic Industries Association of the USA, May 1979

³ MOD UK DEF-5351, Specification for Tubing, Waveguide; Standard of the Ministry of Defence of the United Kingdom

⁴ The cut-off frequency is given by $f_c = c_0/(2a)$ with $c_0 = 299792458 \text{ ms}^{-1}$ and the waveguide width

⁵ This waveguide is sometimes referred to as WR 6

VSWR CONVERSION TABLE

VSWR	Reflection (r)	Return loss (dB)	VSWR	Reflection (r)	Return loss (dB)
1.010	0.005	46.1	1.430	0.177	15.0
1.015	0.007	42.6	1.440	0.180	14.9
1.020	0.010	40.1	1.450	0.184	14.7
1.025	0.012	38.2	1.460	0.187	14.6
1.030	0.015	36.6	1.470	0.190	14.4
1.035	0.017	35.3	1.480	0.194	14.3
1.040	0.020	34.2	1.490	0.197	14.1
1.045	0.022	33.1	1.500	0.200	14.0
1.050	0.024	32.3	1.510	0.203	13.8
1.055	0.027	31.4	1.520	0.206	13.7
1.060	0.029	30.7	1.530	0.209	13.6
1.065	0.031	30.0	1.540	0.213	13.4
1.070	0.034	29.4	1.550	0.216	13.3
1.075	0.036	28.8	1.560	0.219	13.2
1.080	0.038	28.3	1.570	0.222	13.1
1.085	0.041	27.8	1.580	0.225	13.0
1.090	0.043	27.3	1.590	0.228	12.8
1.095	0.045	26.9	1.600	0.231	12.7
1.100	0.048	26.4	1.610	0.234	12.6
1.110	0.052	25.7	1.620	0.237	12.5
1.120	0.057	24.9	1.630	0.240	12.4
1.130	0.061	24.3	1.640	0.242	12.3
1.140	0.065	23.7	1.650	0.245	12.2
1.150	0.070	23.1	1.660	0.248	12.1
1.160	0.074	22.6	1.670	0.251	12.0
1.170	0.078	22.1	1.680	0.254	11.9
1.180	0.083	21.7	1.690	0.257	11.8
1.190	0.087	21.2	1.700	0.259	11.7
1.200	0.091	20.8	1.710	0.262	11.6
1.210	0.095	20.4	1.720	0.265	11.5
1.220	0.099	20.1	1.730	0.267	11.5
1.230	0.103	19.7	1.740	0.270	11.4
1.240	0.107	19.4	1.750	0.273	11.3
1.250	0.111	19.1	1.760	0.275	11.2
1.260	0.115	18.8	1.770	0.278	11.1
1.270	0.119	18.5	1.780	0.281	11.0
1.280	0.123	18.2	1.790	0.283	11.0
1.290	0.127	17.9	1.800	0.286	10.9
1.300	0.130	17.7	1.810	0.288	10.8
1.310	0.134	17.4	1.820	0.291	10.7
1.320	0.138	17.2	1.830	0.293	10.7
1.330	0.142	17.0	1.840	0.296	10.6
1.340	0.145	16.8	1.850	0.298	10.5
1.350	0.149	16.5	1.860	0.301	10.4
1.360	0.153	16.3	1.870	0.303	10.4
1.370	0.156	16.1	1.880	0.306	10.3
1.380	0.160	15.9	1.890	0.308	10.2
1.390	0.163	15.7	1.900	0.310	10.2
1.400	0.167	15.6	1.910	0.313	10.1
1.410	0.170	15.4	1.920	0.315	10.0
1.420	0.174	15.2	1.930	0.317	10.0

On our website you will find a VSWR converter tool under the Downloads section.

INDEX

Part Number	Page	Part Number	Page	Part Number	Page
15 31 06.....	58	63 48 08.....	76	83 50 55.....	27
15 31 07.....	59	63 49 11.....	84	83 50 56.....	20
15 31 18.....	60	63 49 12.....	81	83 50 58.....	21
15 31 27.....	51	63 49 13.....	82	83 50 59.....	22
15 31 30.....	65	63 49 14.....	83	83 50 60.....	24
15 31 33.....	49	63 50 05.....	88	83 50 62.....	23
15 31 39.....	57	63 50 14.....	89	83 50 68.....	33
15 31 46.....	55	63 50 15.....	90	83 50 77.....	36
15 31 50.....	63	63 50 16.....	91	83 50 87.....	37
15 31 51.....	64	63 50 56.....	106	83 50 88.....	39
15 31 58.....	62	63 50 58.....	107	83 50 90.....	38
15 31 64.....	52	63 52 40.....	104	83 50 91.....	34
15 31 66.....	56	63 52 44.....	105	83 50 92.....	99
15 31 67.....	50	63 53 23.....	77	83 50 97.....	28
15 31 68.....	53	63 57 07.....	95	83 50 98.....	32
15 31 71.....	54	63 57 09.....	92	84 06 01.....	44
15 31 89.....	48	63 57 10.....	93	94 54 20.....	42
15 31 92.....	61	63 57 17.....	98	94 54 21.....	40
52 90 13.....	11	63 57 18.....	94	94 54 36.....	41
53 23 32.....	69	63 57 20.....	87		
53 23 33.....	68	63 57 21.....	85		
53 23 48.....	72	63 57 22.....	86		
53 23 49.....	70	63 57 25.....	96		
53 23 52.....	73	63 57 26.....	97		
53 25 17.....	71	63 62 94.....	100		
54 93 71.....	17	63 62 95.....	100		
54 93 75.....	15	63 62 96.....	100		
54 93 97.....	10	63 62 97.....	100		
54 95 81.....	14	82 10 03.....	43		
54 95 82.....	16	83 50 38.....	30		
54 95 99.....	13	83 50 44.....	29		
54 97 57.....	12	83 50 45.....	35		
63 47 36.....	79	83 50 47.....	31		
63 47 37.....	80	83 50 50.....	25		
63 47 39.....	78	83 50 54.....	26		

